

Series 100 Valves



avfi
www.avfi.com.au



avfi p/l
54 Enterprise Drive
Bundoora Vic 3083
p: 03 8467 0000
f: 03 8467 0099
e: avfi@avfi.com.au

Contents

Dorot Series 100 – General	4
----------------------------	---

Technical Data

Available Models	6
------------------	---

Design Specifications	6
-----------------------	---

Diaphragm Selection Table	7
---------------------------	---

Dimensions and Weights	8
------------------------	---

Main Components	10
-----------------	----

Control Functions

M	Manually Controlled Valve	12
---	---------------------------	----

EL	Solenoid Controlled Valve	13
----	---------------------------	----

RC	Hydraulic Remote Controlled Valve	14
----	-----------------------------------	----

PR	Pressure Reducing Valve	15
----	-------------------------	----

PS	Pressure Sustaining & Relief Valve	16
----	------------------------------------	----

DI	Pressure Differential Sustaining Valve	17
----	--	----

FR	Flow Control Valve	18
----	--------------------	----

FE	Excessive Flow Shut-off Valve	19
----	-------------------------------	----

FL	Modulating Float Controlled Valve	20
FLEL	Electric Float Controlled Valve	21
FLDI	Differential Float Controlled Valve	22
AL	Altitude Pilot Controlled Valve	23
BC	Booster Pump Control Valve	24
DW	Deep Well (Borehole) Pump Control Valve	25
RE	Surge Anticipating Valve	26
QR	Quick Pressure-relief Valve	27
TO	Two Stage Opening Addition	28
SP	Surge Preventing Stepped-Closure Addition	29
EC	PLC Controlled Valve	30
DE	Deluge Dry-pipe and Pre-action Valves	31
Pilots and Accessories		32
Other Dorot Products		34
Typical Applications		35

General

Dorot Series 100

The direct sealing diaphragm valves were introduced to the world market for the first time by DOROT CONTROL VALVES at 1982. This valve is operated by the pressure of the pipeline and is used for various control applications in water supply, fire fighting, industrial, sewage and irrigation systems.

The only moving component is a reinforced diaphragm, which:

- a. Drip tight seals the liquid passage in the closed valve
- b. Allows free passage in the fully open valve with minimal obstruction to the flow line
- c. Throttles the flow passage in the modulating valve, as dictated by the pressure in the control chamber

The valve can be closed or modulated using the line pressure or an external separate pressure source that is equal or higher than the line pressure.

Dorot S-100 valves are made for easy, inline maintenance, executed also by unskilled personal using basic tools.

There are no shafts, bearings or seals that may corrode and there is no wear and tear by dirty abrasive water or chemicals.

Features and benefits

- Structural simplicity
- Superb design featuring exceptionally low pressure losses at high flow rates
- Can be used for regulating from no-flow to maximal flow with no need for additional throttling devices or by-pass valves
- For natural liquids, sea water and industrial effluents
- A wide selection of materials, coating and diaphragm types
- All valve models fit a wide variety of control applications using Dorot pilot valves



Principle of operation

3-way control system

The main valve is controlled by a manually, electrically or pressure actuated selector that:

- 1 Introduces the upstream pressure or an external pressure source to the valve's control chamber, thus pressing the valve diaphragm from top to a closed position.
- 2 Opens the valve by relieving the pressure from the control chamber and enabling the internal pressure in the line to push the valve diaphragm up and creating an unrestricted, full flow passage.
- 3 Shuts all passages to and from the control chamber, thus keeping the main valve in a fixed position. This position does not exist in devices used for ON/OFF control applications but is necessary in modulating valves.

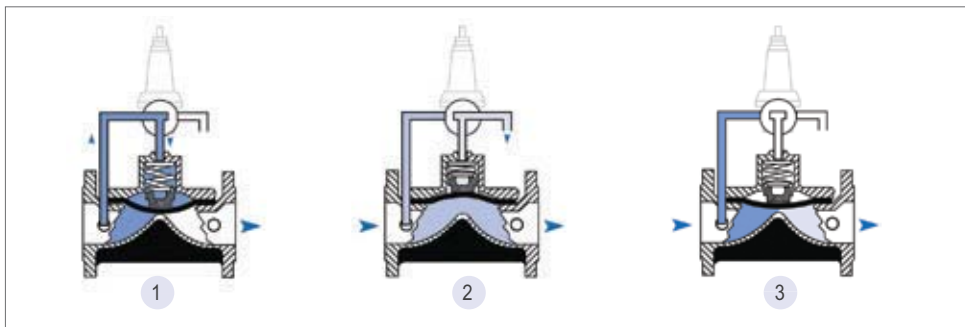

2-way control system

A control system that consist of two restrictions:

- a. A fixed restriction at the upstream side of the control system (nozzle or needle valve)
- b. ON/OFF device (valve, relay or solenoid) or a modulating pilot valve with a larger passage than restriction 'a' that is installed at the downstream side of the control system. The main valve position is affected by the downstream pilot valve 'b' in the following ways:

- 1 When the pilot valve is closed, no water can be vented to the downstream and the main valve is closed by the upstream pressure, introduced into the valve control chamber through the restriction 'a'.
- 2 Opening the valve is enabled when the pilot 'b' is fully open and allows the drainage of pressure in the control chamber to the down stream. At this position the pressure in the control chamber nearly equals that of the downstream.
- 3 Throttling pilot valve 'b' so the flow running through it equals the flow entering through the restriction 'a', keeps a fixed volume of water in the control chamber and the main valve in a fixed position.

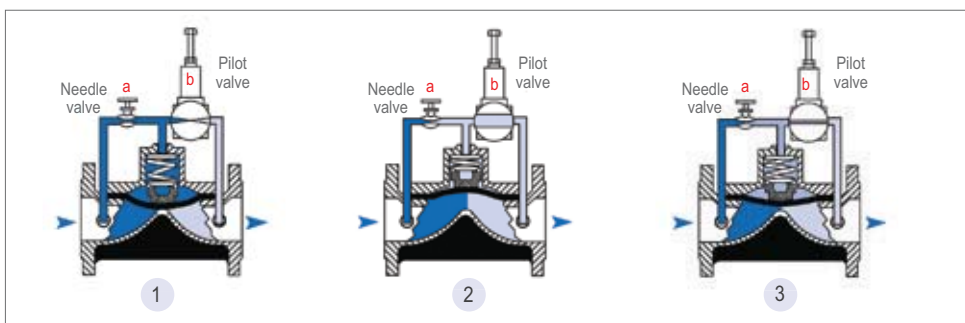

Available Models

Pattern													
Type	44	45	53	47	87	77	82	84	53A	91	67	94	
Connection	Threaded	Threaded	Victaulic®	Flanged	Flanged	Flanged	Flanged	Threaded	Victaulic®	Threaded	Flanged	Threaded	
Material	Cast Iron	Bronze	Cast Iron	Cast Iron	Bronze	Ductile Iron	Cast Iron	Cast Iron	Cast Iron	Bronze	Ductile Iron	Ductile Iron	
Max. Pressure				16bar / 230psi								25bar / 360psi	
Available Sizes	mm	inch											
	20	3/4	•	•									
	25	1	•	•									
	40	1 1/2	•	•	•			•		•			
	50	2	•	•	•	•	•	•		•	•	•	
	65	2 1/2	•	•				•					
	80	3 2/3	•	•	•			•		•			
	80	3	•	•	•	•	•	•	•		•		
	100	4			•	•	•	•	•		•		
	150	6			•	•	•	•			•		
	200	8 6/8			•	•	•						
	200	8			•	•	•				•		
	250	10			•	•	•				•		
	300	12			•	•	•						
	350	14			•	•	•						
400	16					•				•			
450	18					•				•			
500	20					•				•			
600	24					•				•			

Design Specifications

Materials	Standard	Optional *
Body and Bonnet	Cast Iron, Ductile Iron, Bronze	Cast Steel, Stainless Steel
Diaphragm	Natural Rubber	NBR ,EPDM ,Neoprene
Spring	SST 302	SST 316
Nuts And Bolts	Coated Steel	SST
Coating	Polyester	Epoxy, Nylon, Rubber

Connections	Standard	Optional *
Flanges	ISO 2084, 2441, 5752	ANSI B16 JIS B22 AS 10
Threads	F-BSP	F-NPT
Control Bores	1/8", 1/4", 1/2" NPT	

* Others Upon Request

Non Standard Bonnets

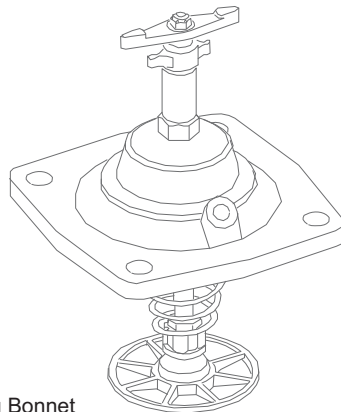

Throttling Bonnet

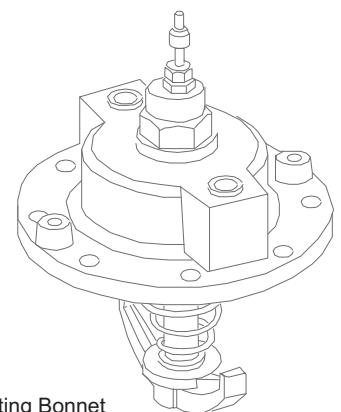

Position Indicating Bonnet

Diaphragm Selection Table*

Diameter		Type	No.	Pressure Range	
mm	inch			mwc	psi
20, 25	3/4", 1"	Standard	18	12-160	17-230
		Low Pressure	85	5-100	7-140
40	1 1/2"	Standard	13	12-160	17-230
		S. Low Pressure	82	5-50	7-70
50, 65	2", 2 1/2", 323	Standard	03	15-160	21-230
		Low Pressure	02	7-100	10-140
		S. Low Pressure	12	4-50	6-70
		Extreme	60	20-160	28-230
50HP	2"HP	High Pressure	69	10-250	15-360
80, 100	3", 4"	Standard	32	12-160	17-230
		Low Pressure	05	4-100	6-140
		Extreme	61	20-160	28-230
80HP	3"HP	High Pressure	70	10-250	15-360
100HP	4"HP	High Pressure	71	10-250	15-360
150	6", 868	Standard	62	20-160	28-230
		Low Pressure	09	5-100	7-140
		S. Low Pressure	91	2-60	3-85
150HP	6"HP	High Pressure	72	10-250	15-360
200, 300, 350	8", 12", 14"	Standard	36	7-160	10-230
		Low Pressure	37	2-100	3-140
		Extreme	63	20-160	28-230
200HP	8"HP	High Pressure	73	10-250	15-360
250	10"	Standard	40	7-160	10-230
		Low Pressure	50	2-100	3-140
250HP, 400HP, 500HP, 600HP	10"HP, 16"HP, 20"HP, 24"HP	High Pressure	78	10-250	15-360
		Low Pressure	92	2-100	3-140

* Standard Diaphragm: Nylon Reinforced Natural Rubber. Optional Materials: Nitrile, EPDM, Neoprene Available Upon Request.

** HP = High Pressure

Pressure Rating

Pressure rating of series 100 valves is body strength, connection standard and diaphragm type.

Pressure rating of valve body of standard models: 16 Bar / 230 psi.

Pressure rating of valve body of high pressure models: 25 Bar / 360 psi.

Connection standard is marked on the identification plate, assembled on the valve body.

Diaphragms operation pressure range is presented at the above table.

Dimensions and Weights

Straight Flow, Threaded Connection

Valve Size		L				H				D		W		Weight			
		Cast Iron		Bronze		Cast Iron		Bronze						Cast Iron		Bronze	
mm	inch	mm	inch	mm	inch	mm	inch	mm	inch	mm	inch	mm	inch	kg	lbs	kg	lbs
20	3/4	115	4 ¹⁷ / ₃₂	112	4 ¹³ / ₃₂	43	1 ¹¹ / ₁₆	43	1 ¹¹ / ₁₆	20	25 ⁵ / ₃₂	68	2 ⁴³ / ₆₄	1	2.2	1	2.2
25	1	120	4 ²³ / ₃₂	119	4 ¹¹ / ₁₆	52	2 ³ / ₆₄	52	2 ³ / ₆₄	24	15 ¹ / ₁₆	68	2 ⁴³ / ₆₄	1	2.2	1	2.2
40	1 1/2	170	6 ¹¹ / ₁₆	149	5 ⁵⁵ / ₆₄	93	3 ²¹ / ₃₂	86	3 ³ / ₈	33	1 ¹⁹ / ₆₄	93	3 ²¹ / ₃₂	2.2	4.9	1.8	4
50	2	188	7 ¹³ / ₃₂	184	7 ¹⁵ / ₆₄	115	4 ¹⁷ / ₃₂	101	3 ³¹ / ₃₂	42	1 ⁴¹ / ₆₄	112	4 ¹³ / ₃₂	3.2	7	2.6	5.7
65	2 1/2	219	8 ⁵ / ₈	212	8 ¹¹ / ₃₂	118	4 ⁴¹ / ₆₄	109	4 ⁹ / ₃₂	46	1 ¹³ / ₁₆	112	4 ¹³ / ₃₂	3.6	7.9	3.4	7.5
80LF*	3 2/3	225	8 ⁵⁵ / ₆₄	221	8 ¹¹ / ₃₂	126	4 ⁶¹ / ₆₄	116	4 ⁹ / ₁₆	54	2 ¹ / ₈	112	4 ¹³ / ₃₂	4.5	9.9	3.9	8.5
80	3	316	12 ¹³ / ₆₄	316	12 ¹³ / ₆₄	135	5 ⁵ / ₁₆	135	5 ⁵ / ₁₆	53	2 ⁵ / ₆₄	200	7 ⁷ / ₈	11	24		

* LF = Low Flow

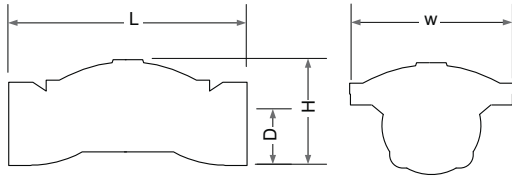

Straight Flow, Grooved Connection (Vic.)

Valve Size		L		H		D		W		Weight	
mm	inch	mm	inch	mm	inch	mm	inch	mm	inch	kg	lbs
40	1 1/2	177	6 ³¹ / ₃₂	81	3 ³ / ₁₆	26	1 ¹ / ₆₄	93	3 ²¹ / ₃₂	1.8	4
50	2	190	7 ³¹ / ₆₄	100	3 ¹⁵ / ₁₆	33	1 ¹⁹ / ₆₄	112	4 ¹³ / ₃₂	2.6	5.7
80	3 2/3	201	7 ²⁹ / ₃₂	120	4 ²³ / ₃₂	47	1 ²⁷ / ₆₄	112	4 ¹³ / ₃₂	3	6.6
80LF	3	286	11 ¹ / ₄	124	4 ⁷ / ₈	47	1 ²⁷ / ₆₄	200	7 ⁷ / ₈	11	24.3
100	4	317	12 ¹⁵ / ₃₂	133	5 ¹⁵ / ₆₄	60	2 ²³ / ₆₄	194	7 ⁴¹ / ₆₄	12	26.4
150	6	392	15 ²⁷ / ₆₄	250	9 ²⁷ / ₃₂	82	3 ¹ / ₃₂	300	11 ¹³ / ₁₆	31	68.3

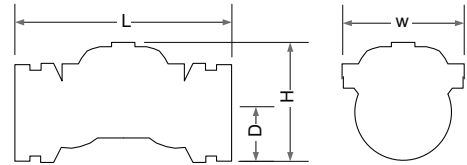

Angle Flow, Grooved Connection (Vic.)

Valve Size		H		D		W		Weight	
mm	inch	mm	inch	mm	inch	mm	inch	kg	lbs
80	3	240	9 ⁷ / ₁₆	170	6 ¹¹ / ₁₆	200	7 ⁷ / ₈	10.5	23.1
100	4	250	9 ²⁷ / ₃₂	185	7 ⁹ / ₃₂	200	7 ⁷ / ₈	11.5	25.4

Angle Flow, Threaded Connection

Valve Size		H		D		W		Weight	
mm	inch	mm	inch	mm	inch	mm	inch	kg	lbs
40	1 1/2	110	4 ²¹ / ₆₄	75	2 ⁶ / ₆₄	93	3 ²¹ / ₃₂	1.7	3.7
50	2	136	5 ¹¹ / ₃₂	90	3 ³⁵ / ₆₄	112	4 ¹³ / ₃₂	2.4	5.3
80LF	3 2/3	165	6 ¹ / ₂	114	4 ³ / ₆₄	112	4 ¹³ / ₃₂	3.6	7.9
80	3	239	9 ¹³ / ₃₂	145	5 ⁴⁵ / ₆₄	200	7 ⁷ / ₈	10.8	23.8

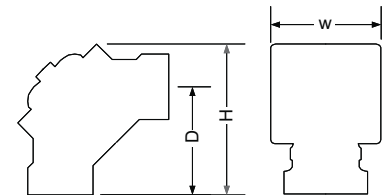

Angle Flow, Flanged Connection

Valve Size		H		D		W		Weight	
mm	inch	mm	inch	mm	inch	mm	inch	kg	lbs
80	3	278	9 ¹⁵ / ₁₆	174	8 ²⁷ / ₃₂	200	7 ⁷ / ₈	18	39.7
100	4	300	11 ¹³ / ₁₆	185	7 ⁹ / ₃₂	230	9 ³ / ₆₄	21	46.3
150	6	380	14 ⁶¹ / ₆₄	230	9 ³ / ₆₄	300	11 ¹³ / ₁₆	45	99.2

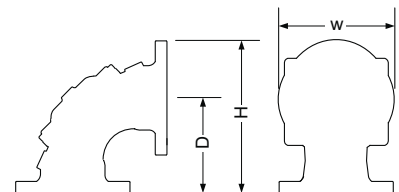

Dimensions and Weights

Straight Flow, Flanged Connection - Standard Models 16 Bar / 230 psi

Valve Size		L		H		D		W		Weight					
mm	inch	mm	inch	mm	inch	mm	inch	mm	inch	Cast Iron		Duct. Iron		Bronze	
mm	inch	mm	inch	mm	inch	mm	inch	mm	inch	kg	lbs	kg	lbs	kg	lbs
50	2	200	7 ⁷ / ₈	166	6 ¹⁷ / ₃₂	85	3 ¹¹ / ₃₂	166	6 ¹⁷ / ₃₂	7.2	15.8	7.7	17	8	17.6
80LF	323	200	7 ⁷ / ₈	202	7 ⁶¹ / ₆₄	105	4 ¹ / ₈	200	7 ⁷ / ₈	11	24.3	11.8	26		
80	3	285	11 ⁷ / ₃₂	200	7 ⁷ / ₈	105	4 ¹ / ₈	200	7 ⁷ / ₈	17	37.5	18.2	40.1	19	42
100	4	305	12	230	9 ³ / ₆₄	110	4 ²¹ / ₆₄	230	9 ³ / ₆₄	22	48.5	24	53	24	53
150	6	390	15 ¹¹ / ₃₂	314	12 ²³ / ₆₄	145	5 ⁴⁵ / ₆₄	300	11 ¹³ / ₁₆	46	101	49	108	51	112
200LF	868	385	15 ¹¹ / ₃₂	350	13 ²⁵ / ₃₂	170	6 ¹¹ / ₁₆	365	14 ³ / ₈	50	110	54	119		
200	8	460	18 ⁷ / ₆₄	400	15 ³ / ₄	170	6 ¹¹ / ₁₆	365	14 ³ / ₈	80	176	86	190	89	196
250	10	535	21 ¹ / ₁₆	445	17 ¹³ / ₆₄	205	8 ¹ / ₁₆	440	17 ⁹ / ₁₆	117	258	125	276	131	289
300	12	580	22 ⁵³ / ₆₄	495	19 ⁷ / ₁₆	240	9 ⁷ / ₁₆	490	19 ⁹ / ₃₂	156	344	167	368	147	324
350	14	580	22 ⁵³ / ₆₄	495	19 ⁷ / ₁₆	270	10 ⁵ / ₈	540	21 ¹ / ₄	182	401	172	379	180	397

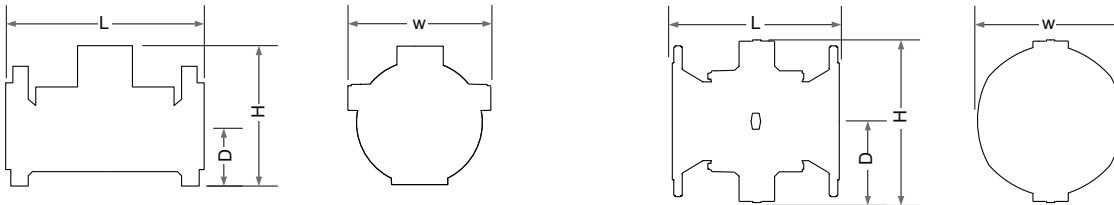

Straight Flow, Flanged Connection - High Pressure Models 25 Bar / 360 psi

Valve Size		L		H		D		W		Weight	
mm	inch	mm	inch	mm	inch	mm	inch	mm	inch	kg	lbs
50	2	228	8 ³¹ / ₃₂	169	6 ²¹ / ₃₂	85	3 ¹¹ / ₃₂	175	6 ⁵⁷ / ₆₄	10	22
50TH	2TH	250	9 ²⁷ / ₃₂	120	4 ²³ / ₃₂	42	1 ²¹ / ₃₂	175	6 ⁵⁷ / ₆₄	6	13
80	3	310	12 ¹³ / ₆₄	237	9 ²¹ / ₆₄	105	4 ¹ / ₈	200	7 ⁷ / ₈	30	66.1
100	4	356	14 ¹ / ₆₄	263	10 ¹¹ / ₃₂	120	4 ²³ / ₃₂	260	10 ¹⁵ / ₆₄	38	83.8
150	6	436	17 ⁵ / ₃₂	378	14 ⁷ / ₈	150	5 ⁵⁷ / ₆₄	320	12 ¹⁹ / ₃₂	75	165.3
200	8	530	20 ⁵⁵ / ₆₄	481	18 ¹⁵ / ₁₆	180	7 ¹ / ₃₂	400	15 ³ / ₄	123	271
250	10	636	25 ¹ / ₃₂	546	21 ¹ / ₂	215	8 ¹⁵ / ₃₂	495	19 ⁷ / ₁₆	190	419
400	16	709	27 ²⁹ / ₃₂	830	32 ⁴³ / ₆₄	310	12 ¹³ / ₆₄	830	32 ⁴³ / ₆₄	433	955
450	18	715	28 ⁹ / ₃₂	830	32 ⁴³ / ₆₄	340	13 ²⁵ / ₆₄	830	32 ⁴³ / ₆₄	460	1014
500	20	900	35 ⁷ / ₁₆	970	38 ³ / ₁₆	490	19 ⁹ / ₃₂	980	38 ³⁷ / ₆₄	674	1486
600	24	900	35 ⁷ / ₁₆	970	38 ³ / ₁₆	490	19 ⁹ / ₃₂	980	38 ³⁷ / ₆₄	696	1534

* TH = Threaded

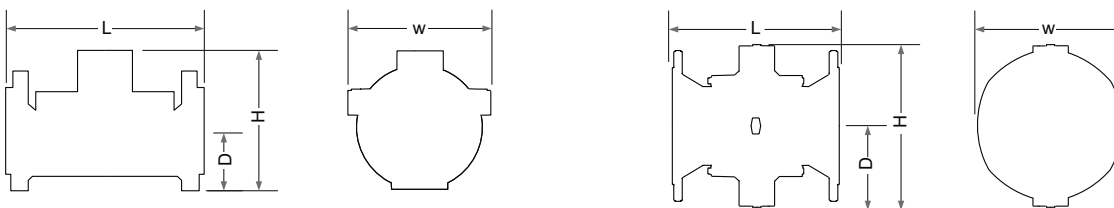

Series 100 Valves

Technical Data

Hydraulic Performance

Valve Size	mm	20	25	40	50	65	80	80LF	100	150	200LF	200	250	300	350	400	450	500	600
	inch	3/4	1	1 1/2	2	2 1/2	323	3	4	6	868	8	10	12	14	16	18	20	24
Max. Flow Continuance	m ³ /hr	6	10	25	40	40	40	90	160	350	350	620	970	1400	1400	2500	2500	3890	5500
	gpm	26.4	44	110	176	176	176	396	700	1540	1540	2730	4268	6160	6160	11000	11000	17116	24200
Max. Flow Intermittent	m ³ /hr	16	27	68	109	109	109	245	273	955	955	1309	2645	3818	3818	6818	6818	10609	10609
	gpm	72	120	300	480	480	480	1080	1200	4200	4200	5760	11640	16800	16800	30000	30000	46680	46680
Minimal Flow	m ³ /hr	< 1																	
	gpm	< 5																	
Kv	m ³ /hr @ 1 bar	17	17	64	95	95	95	170	220	600	670	800	1250	1900	1900	2600	2600	4600	4600
Cv	gpm @ 1 psi	20	20	75	110	110	110	200	260	700	780	930	1460	2220	2220	3030	3030	5370	5370
Kv*	m ³ /hr @ 1 bar	-	-	-	78	-	-	120	200	550	-	800	1300	-	-	2600	2600	4600	4600
Cv*	gpm @ 1 psi	-	-	-	91	-	-	140	230	640	-	930	1520	-	-	3030	3030	5370	5370

* High pressure models

$$\Delta P(\text{Bar}) = \left(\frac{Q[\frac{\text{m}^3}{\text{hr}}]}{Kv} \right)^2 \quad \Delta P(\text{Psi}) = \left(\frac{Q[\text{gpm}]}{Cv} \right)^2$$

Headloss Chart

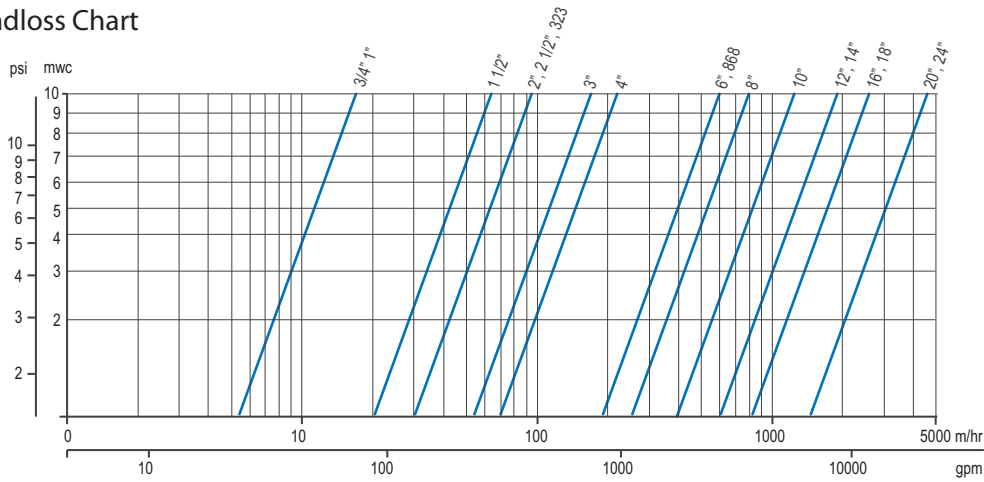

Cavitation Data

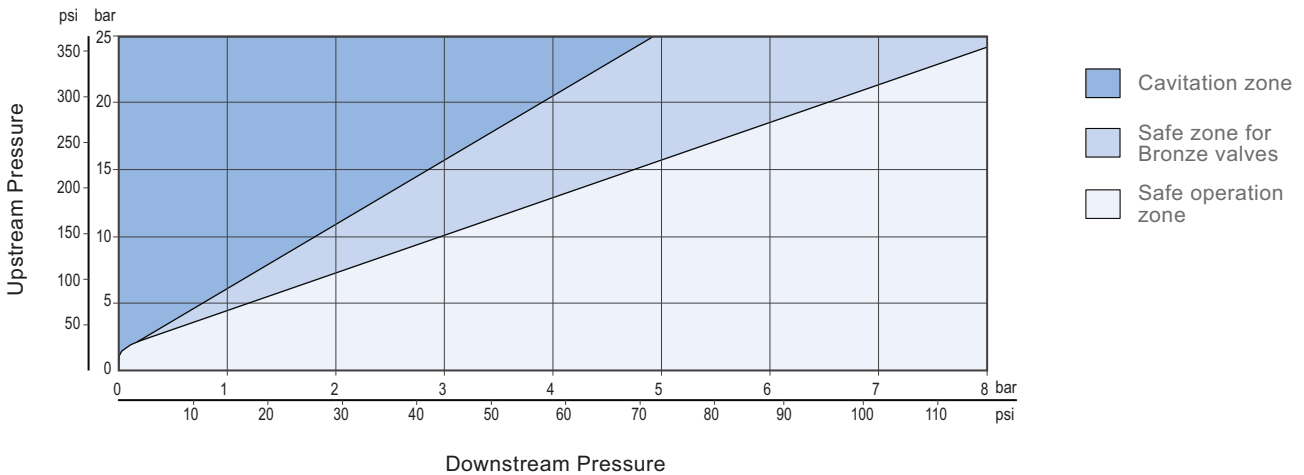

Main Components

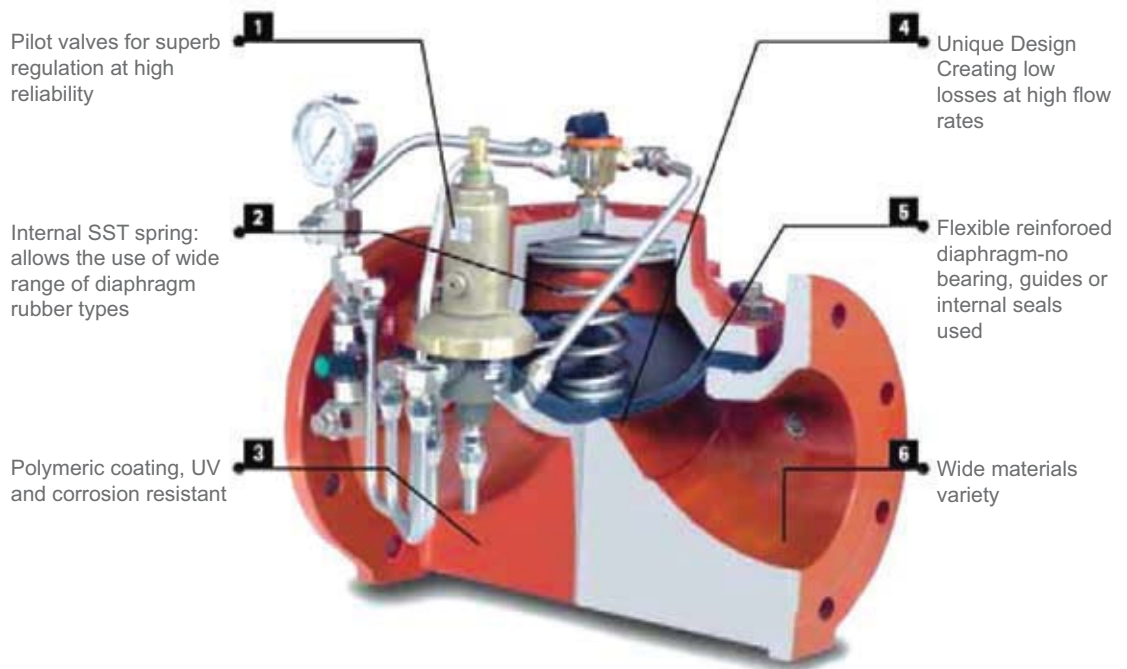

Components

Component No.	Description
1	Body
2	Bonnet
3	Diaphragm
4	Spring
5	Spring Disc
6	Bolt
7	Short Bolt
8	Washer
9	Nut
10	Suspension Ring (Hook)

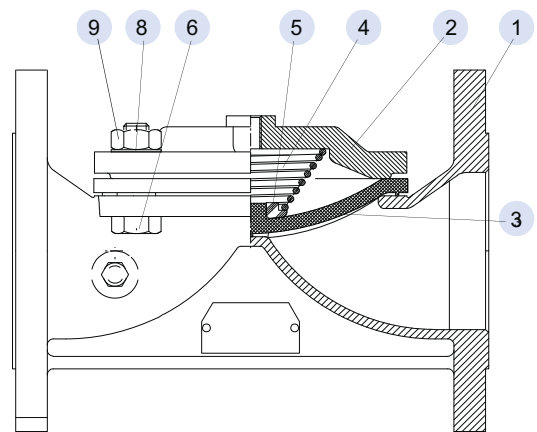
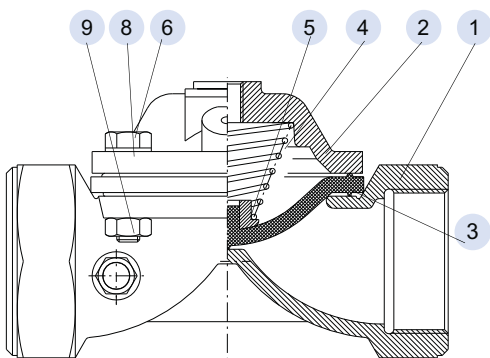
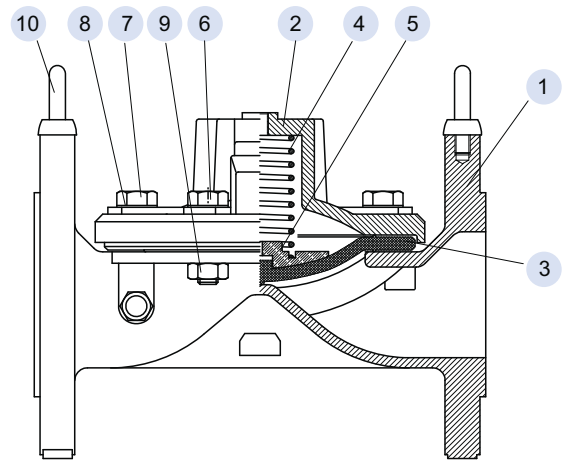

M Manually Controlled Valve

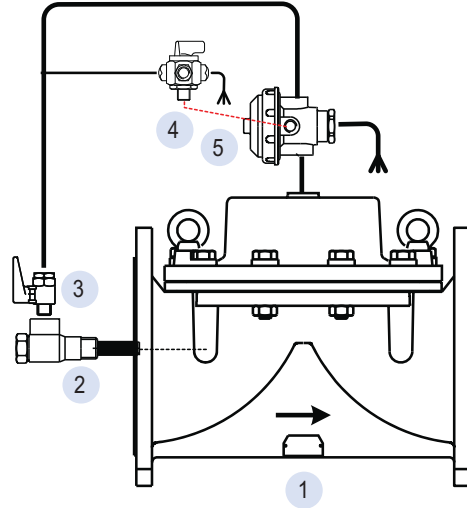

Description

The valve is controlled manually by a three port selector that allows the user to select the closed, opened or remote-controlled position of the valve. The control is effected effortlessly and quickly, even under high pressure conditions

Features

- Effortless open/close activation
- Fast response
- Clog-free operation
- Can be added as manual over-ride to any other control function

Purchase Specifications

The valve will be a direct sealing diaphragm type, which allows inline maintenance. No stem, shaft or guide bearing will be located within the water passage.
 The valve will be activated by the line pressure or by an external hydraulic or pneumatic pressure.
 The valve position will be controlled by a hand operated selector valve. The valve and the controls will be a Dorot Series 100 valve or similar in all aspects.

Quick Sizing

- Valve size same as line or one size smaller
- Maximum flow speed for continuous operation 5.5 m/sec (18 ft/sec)

Design Considerations

- The valve should be suited for the maximal flow and allowed headloss
- Preferred selection of low pressure diaphragms when the valve is expected to stay in open position for long periods

Optional Control System Components:

- 1 Main Valve
- 2 Self-flushing filter
- 3 Cock valve*
- 4 3-way selector valve
- 5 Accelerator relay (optional for valves larger than 150mm/6")

* Optional component

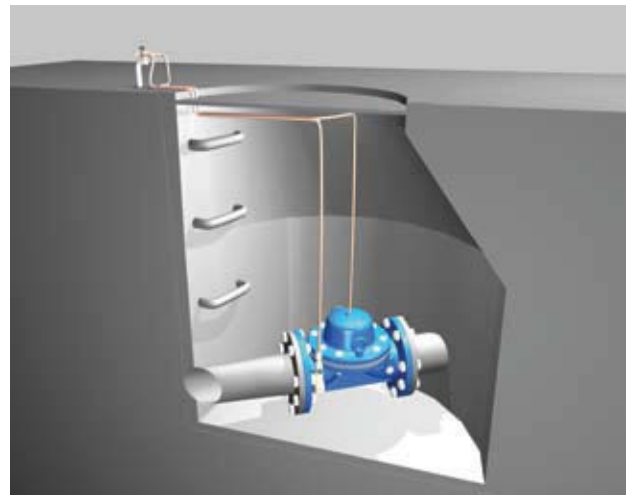

Typical Application

Dorot Manually controlled valve installed in an underground, flooded pit. Manual activation is enabled from top by the selector valve.

EL Solenoid Controlled Valve



Description

A 3-way solenoid valve, activated by an electric current or an electric pulse, opens or closes the main valve. The standard valve is supplied in the “normally closed” position. The “normally open” position is optional. Electric activation can be added to other control applications on request.

Features

- Low power electric activation
- Fast response
- Simple and reliable design
- Can be added as electric over-ride to any other control function

Purchase Specifications

The valve will be hydraulic, direct sealing diaphragm type, which allows inline maintenance. No stem, shaft or guide bearing will be located within the water passage. The valve will be activated by the line pressure or by an external hydraulic or pneumatic pressure. The valve position will be controlled by an electric solenoid valve. The valve and the controls will be a Dorot Series 100 valve or similar in all aspects.

Quick Sizing

- Valve size same as line or one size smaller
- Maximum flow speed for continuous operation 5.5 m/sec (18 ft/sec)

Design Considerations

- The valve should be suited for the maximal flow and allowed headloss
- Prefer selection low pressure diaphragms when the valve is expected to stay in open position for long periods
- The valve can be opened by the electric command (NC) or closed by it (NO). The definition refers to the main valve operation and not the solenoid's characteristics

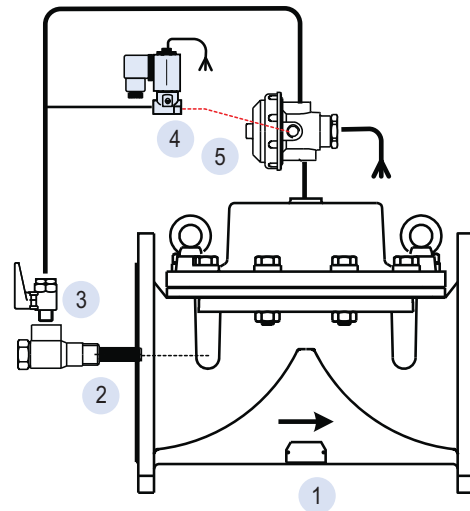

Optional Control System Components:

- 1 Main Valve
- 2 Self-flushing filter
- 3 Cock valve*
- 4 3/2 Solenoid valve
- 5 Accelerator relay (optional for valves larger than 150mm/6")

* Optional component

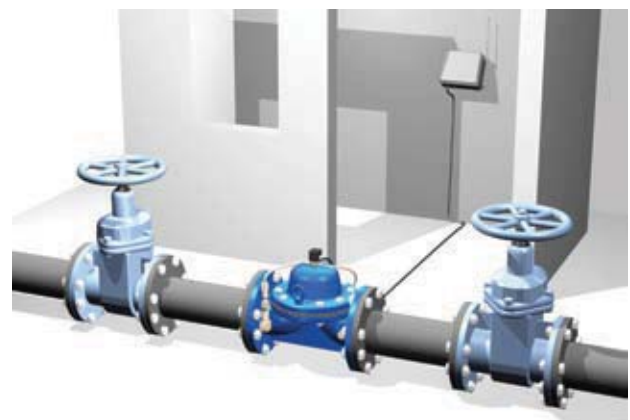

Typical Application

Dorot Solenoid Controlled valve, controlled by a local controller.

RC Hydraulic Remote Controlled Valve

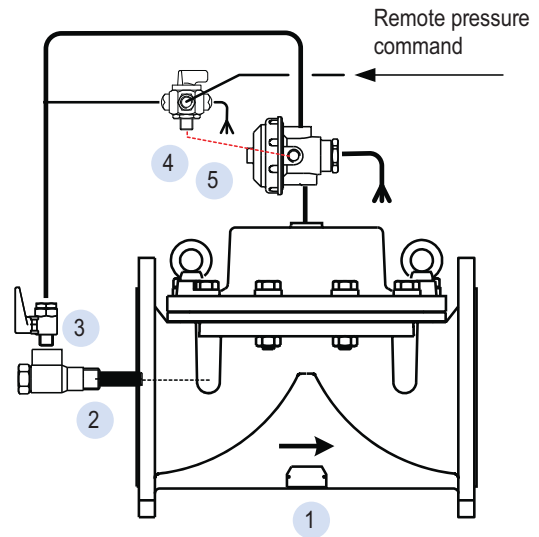

Description

A 3-way relay valve, activated by hydraulic or pneumatic pressure command, opens or closes the main valve. The standard valve is supplied in the “normally closed” position. The “normally open” position is optional. Hydraulic activation can be added to other control applications on request.

Features

- Fast response even for long control lines
- Simple and reliable design
- Can be added as pressure command over-ride to any other control function

Purchase Specifications

The valve will be hydraulic, direct sealing diaphragm type, which allows inline maintenance. No stem, shaft or guide bearing will be located within the water passage. The valve will be activated by the line pressure or by an external hydraulic or pneumatic pressure. The valve position will be controlled by a hydraulic relay. The valve and the controls will be a Dorot Series 100 valve or similar in all aspects.

Quick Sizing

- Valve size same as line or one size smaller
- Maximum flow speed for continuous operation 5.5 m/sec (18 ft/sec)

Design Considerations

- The valve should be suited for the maximal flow and allowed headloss
- Prefer selection low pressure diaphragms when the valve is expected to stay in open position for long periods
- The valve can be opened by the pressure command (NC) or closed by it (NO). The definition refers to the main valve operation and not the relay’s characteristics

Optional Control System Components:

- 1 Main Valve
- 2 Self-flushing filter
- 3 Cock valve*
- 4 Manual over-ride selector valve*
- 5 Accelerator relay (other types are optional)

* Optional component



Typical Application

Dorot Hydraulic Remote Controlled Valve, activated by a remote pressure command.

PR Pressure Reducing Valve



Description

The valve maintains a preset downstream pressure, regardless of upstream pressure or flow rate fluctuation. The main valve is controlled by either a 3-way pilot valve (allowing full opening when upstream pressure drops below the pressure set-point), or by a 2-way pilot valve (creating a minimal differential in open position).

Features

- Accurate, stable control from no-flow to full flow
- Simple and reliable design
- Exceptionally low losses at high flow
- WRAS Approval no. 04251

Purchase Specifications

The valve will be hydraulic, direct sealing diaphragm type, which allows inline maintenance. No stem, shaft or guide bearing will be located within the water passage.

The valve will be activated by the line pressure or by an external hydraulic or pneumatic pressure. The valve will be operated by a pressure reducing pilot valve to achieve constant outlet pressure, regardless of upstream pressure or flow variations. The valve and the controls will be a Dorot Series 100 valve or similar in all aspects.

Quick Sizing

- Valve size same as line or one size smaller
- Maximum flow speed for continuous operation 5.5 m/sec (18 ft/sec)

Design Considerations

- The valve should be suited for the maximal flow and allowed headloss
- In case upstream pressure may drop to the required set pressure, select 3-way control pilot
- Large pressure differentials may cause cavitation damage. Consult Dorot for solutions if such conditions are expected

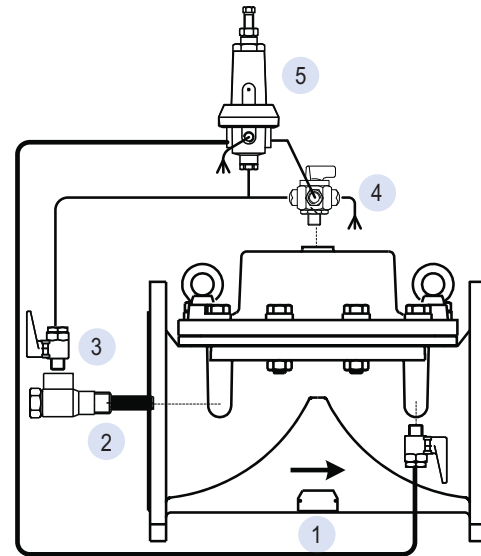

Optional Control System Components:

- 1 Main Valve
- 2 Self-flushing filter
- 3 Cock valve*
- 4 Manual over-ride selector valve*
- 5 3-way pilot valve (other types are optional)

* Optional component

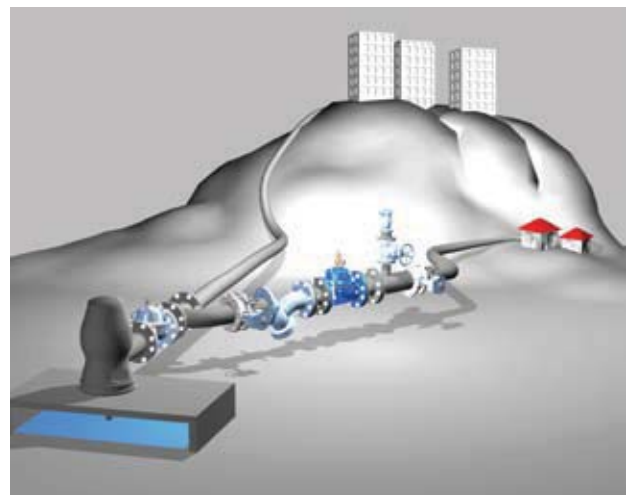

Typical Application

Dorot Pressure Reducing Valve reduces varying supply pressure to a stabilized downstream pressure.

Control Functions

PS Pressure Sustaining & Relief Valve

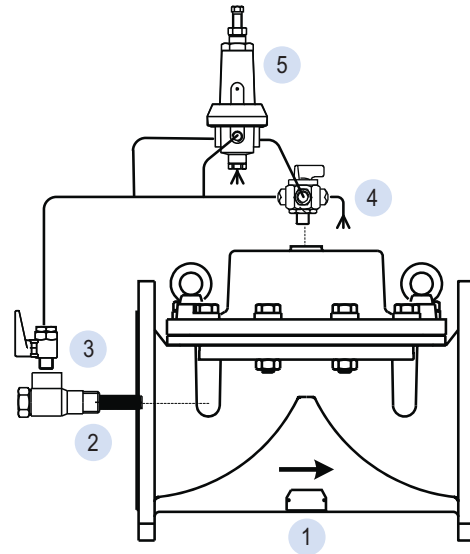

Description

The valve maintains upstream pressure, regardless of flow rate variations. The valve will be in the “closed” position if the upstream pressure drops below the set-point and will fully open when the upstream pressure exceeds the set-point.

Features

- Accurate, stable control from no-flow to full flow
- Simple and reliable design
- Exceptionally low losses at high flow

Purchase Specifications

The valve will be hydraulic, direct sealing diaphragm type, which allows inline maintenance. No stem, shaft or guide bearing will be located within the water passage. The valve will be activated by the line pressure or by an external hydraulic or pneumatic pressure. The valve will be operated by a pressure sustaining pilot valve to maintain constant inlet pressure, regardless of flow variations. The valve and the controls will be a Dorot Series 100 valve or similar in all aspects.

Quick Sizing

- Valve size same as line or one size smaller
- Maximum flow speed for continuous operation 5.5 m/sec (18 ft/sec)

Design Considerations

- The valve should be suited for the maximal flow and allowed headloss
- Check for possible cavitation conditions and consult Dorot in case such conditions are expected

Optional Control System Components:

- 1 Main Valve
- 2 Self-flushing filter
- 3 Cock valve*
- 4 Manual over-ride selector valve*
- 5 3-way pilot valve (other types are optional)

* Optional component

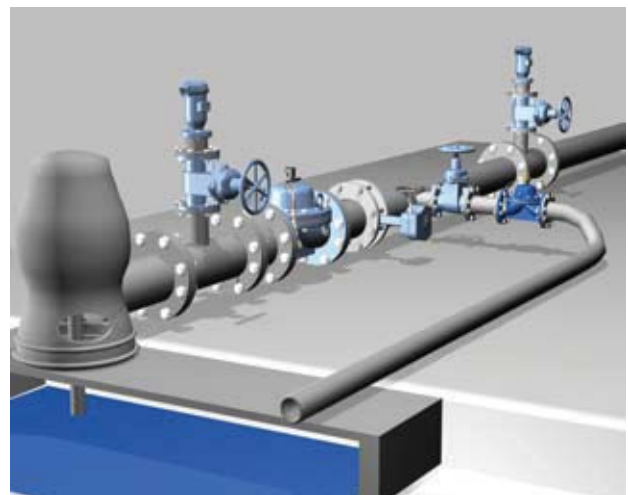

Typical Application

Dorot Pressure Relief Valve relieving pump surplus flow from the system, thus preventing high pressure at low demand conditions.

DI Pressure Differential Sustaining Valve

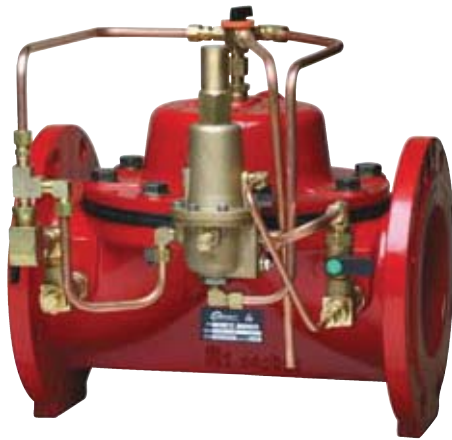

Description

The valve maintains a preset pressure differential between its upstream and downstream sides. The valve can control booster pump discharge, heating and cooling systems, bypass configurations, filters and other similar systems.

Features

- Accurate, stable control from no-flow to full flow
- Simple and reliable design
- Exceptionally low losses at high flow

Purchase Specifications

The valve will be hydraulic, direct sealing diaphragm type, which allows inline maintenance. No stem, shaft or guide bearing will be located within the water passage. The valve will be activated by the line pressure or by an external hydraulic or pneumatic pressure. The valve will be operated by a pressure sustaining differential pilot valve so to maintain a minimal pressure differential, regardless of flow variations.

The valve and the controls will be a Dorot Series 100 valve or similar in all aspects.

Quick Sizing

- Valve size same as line or one size smaller
- Maximum flow speed for continuous operation 5.5 m/sec (18 ft/sec)

Design Considerations

- The valve should be suited for the maximal flow and allowed headloss
- Check for possible cavitation conditions and consult Dorot in case such conditions are expected
- The connection points of the sensing tubes must be selected in locations free of turbulence and local interferences

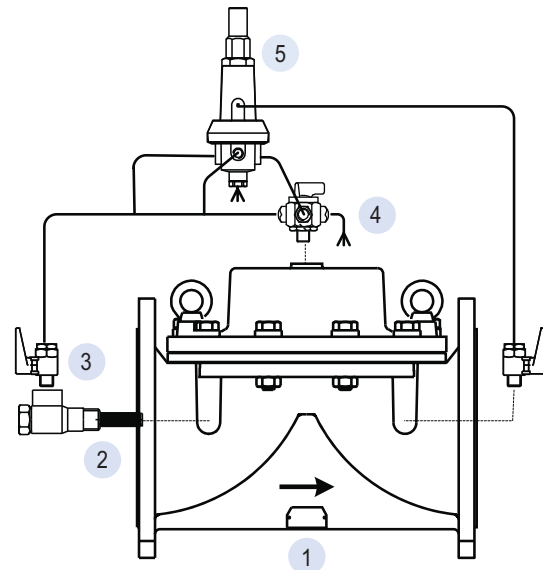

Optional Control System Components:

- 1 Main Valve
- 2 Self-flushing filter
- 3 Cock valve*
- 4 Manual over-ride selector valve*
- 5 3-way pilot valve (other types are optional)

* Optional component

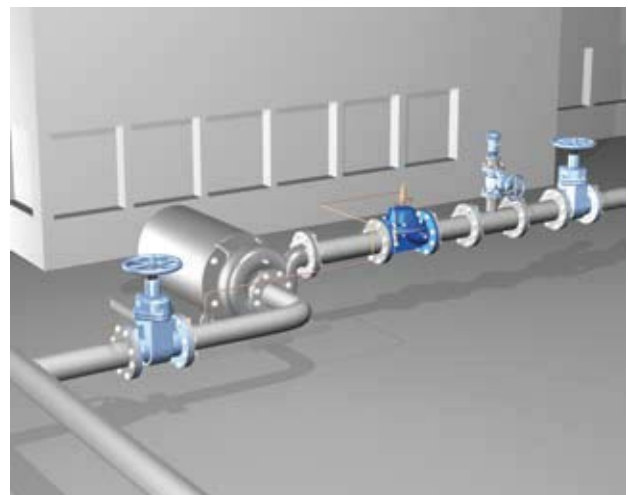

Typical Application

Dorot Pressure Differential Sustaining Valve controls the flow at the discharge of a booster pump whose suction pressure varies.

FR Flow Control Valve

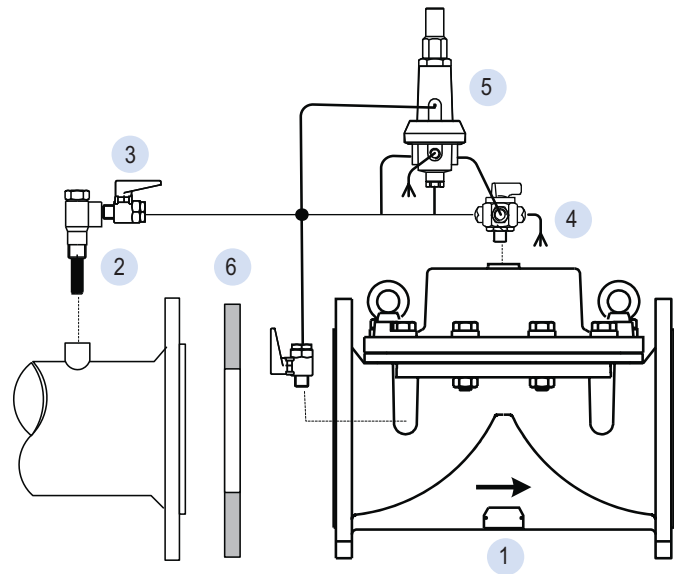

Description

The valve limits the flow rate in the network to a preset value regardless of upstream pressure variations. The valve fully opens when the flow rate drops below the set point.

Features

- Accurate, stable control
- Simple and reliable design
- Low losses when the demand is lower than the set flow

Purchase Specifications

The valve will be hydraulic, direct sealing diaphragm type, which allows inline maintenance. No stem, shaft or guide bearing will be located within the water passage.

The valve will be activated by the line pressure or by an external hydraulic or pneumatic pressure. The valve will be operated by a pressure reducing differential pilot valve for controlling the flow through the main valve, regardless of pressure variations. The valve and the controls will be a Dorot Series 100 valve or similar in all aspects.

Quick Sizing

- Valve size same as line or one size smaller
- Maximum flow speed for continuous operation 5.5 m/sec (18 ft/sec)

Design Considerations

- A 1/2" pressure sensing port should be provided, upstream of the valve
- Check for possible cavitation conditions and consult Dorot in case such conditions are expected
- An additional pressure loss of about 2.5 mwc is created by the orifice plate (at the set flow)

Optional Control System Components:

- 1 Main Valve
- 2 Self-flushing filter
- 3 Cock valve*
- 4 Manual over-ride selector valve*
- 5 3-way differential pilot valve (other types are optional)
- 6 Orifice plate

* Optional component

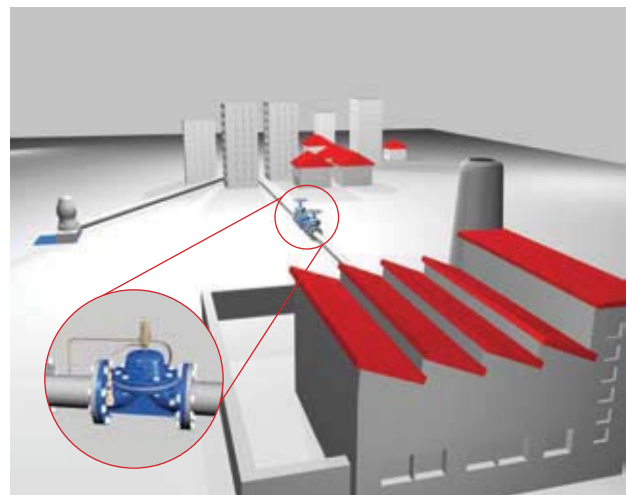

Typical Application

Dorot Flow Control Valve limits the flow to a specific customer.

Control Functions

FE Excessive Flow Shut-off Valve



Description

The valve closes drip tight when the flow rate exceeds the normal value (due to pipe rupture). The valve will manually re-set open after fixing the break.

Features

- Hydraulic burst protection. No electronic controllers are used
- Simple and reliable design
- Low losses

Purchase Specifications

The valve will be hydraulic, direct sealing diaphragm type, which allows inline maintenance. No stem, shaft or guide bearing will be located within the water passage.

The valve will be activated by the line pressure or by an external hydraulic or pneumatic pressure. The valve will be operated by a pressure reducing differential pilot valve for closing when the flow through the main valve exceeds the safe level, regardless of pressure variations. The valve and the controls will be a Dorot Series 100 valve or similar in all aspects.

Quick Sizing

- Valve size same as line or one size smaller
- Maximum flow speed for continuous operation 5.5 m/sec (18 ft/sec)

Design Considerations

- A 1/2" pressure sensing port should be provided, upstream of the valve
- The valve is adjusted to close when the flow rate exceeds the maximal design flow by 10%-20%
- An additional pressure loss of about 2 mwc is created by the orifice plate (at the normal flow)

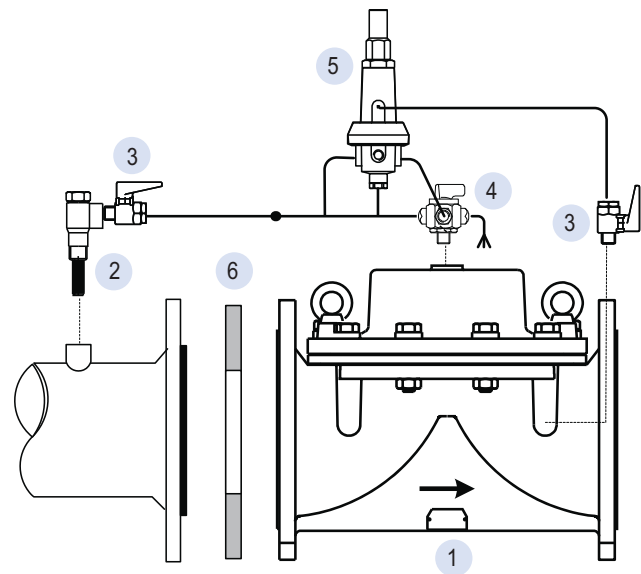

Optional Control System Components:

- 1 Main Valve
- 2 Self-flushing filter
- 3 Cock valve*
- 4 Manual over-ride selector valve*
- 5 3-way differential pilot valve (other types are optional)
- 6 Orifice plate

* Optional component

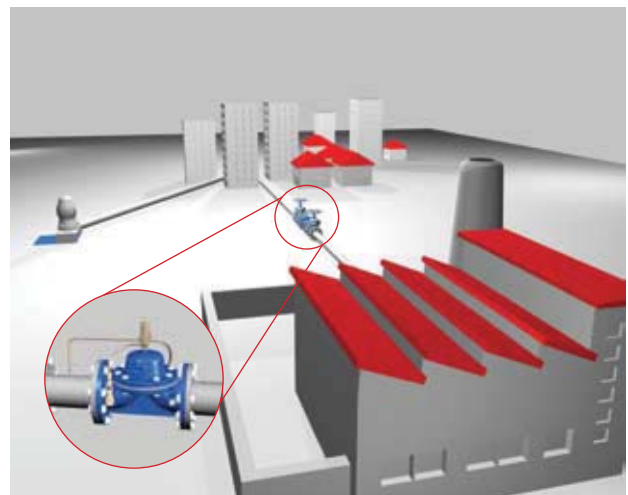

Typical Application

Dorot excessive flow shutoff valve installed to prevent flood damages caused by pipe rupture.

FL Modulating Float Controlled Valve

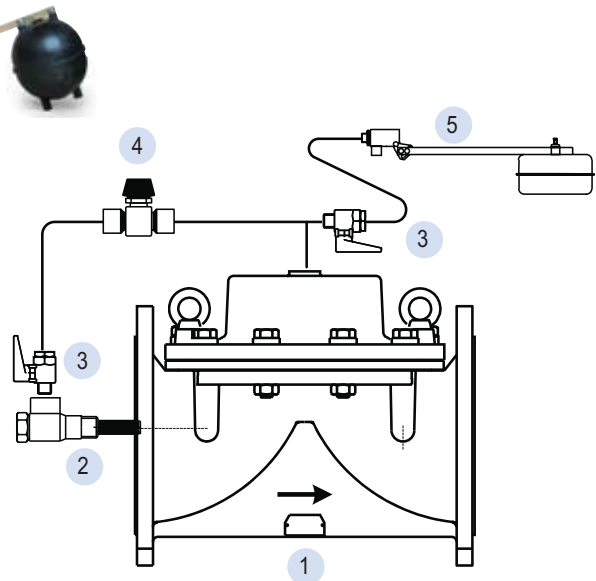

Description

The main valve is controlled by a float valve, located in the tank or reservoir and set at the required maximum water level. The valve maintains the maximum level continuously.

Features

- Accurate and repeatable level control
- Simple and reliable design
- Easy installation and maintenance
- Adjusts the inlet flow to the reservoir's outlet flow
- WRAS Approval no. 0009092

Purchase Specifications

The valve will be hydraulic, direct sealing diaphragm type, which allows inline maintenance. No stem, shaft or guide bearing will be located within the water passage.

The valve will be activated by the line pressure and be operated by a modulating, 2-way float activated pilot valve. The valve and the controls will be a Dorot Series 100 valve or similar in all aspects.

Quick Sizing

- Valve size same as the fill line or one size smaller
- Maximum flow speed for continuous operation 5.5 m/sec (18 ft/sec)

Design Considerations

- The valve should be suited for the maximal flow
- Upstream pressure at closed position should be at least 10m (15psi) higher than the hydrostatic water pressure at the downstream
- Large pressure differentials may cause cavitation damage. Consult Dorot for solutions if such cases are expected
- Prefer use of differential level control in case excessive noise should be avoided (residential areas)

Optional Control System Components:

- 1 Main Valve
- 2 Self-flushing filter
- 3 Cock valve*
- 4 Needle valve
- 5 Modulating float pilot valve

* Optional component

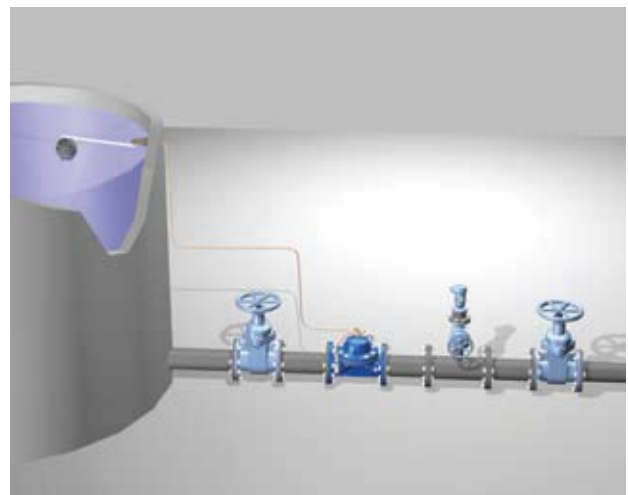

Typical Application

Dorot Modulating Float Controlled valve prevents tank overflow.

FLEL Electric Float Controlled Valve

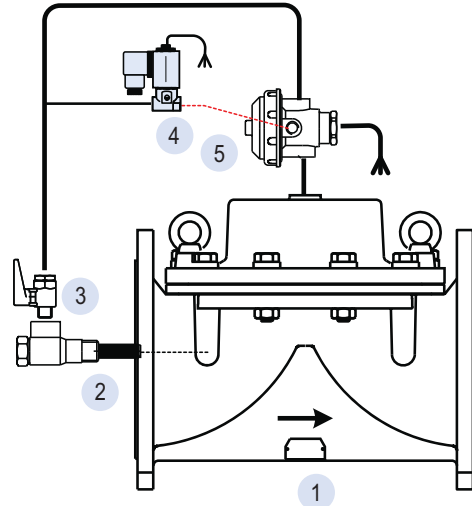

Description

An electric sensor float, located in the tank/reservoir, sends a command to a solenoid controlled valve. The main valve will fully open when the solenoid activated and will close drip tight when the solenoid de-energized, thus enabling accurate and reliable differential level control.

Optional Addition: Stepped Surge-Preventing Closure.

Features

- Accurate and repeatable differential level control
- Low power electric activation
- Fast response
- Simple and reliable design
- Easy installation and maintenance

Purchase Specifications

The valve will be hydraulic, direct sealing diaphragm type, which allows inline maintenance. No stem, shaft or guide bearing will be located within the water passage.

The valve will be activated by the line pressure or by an external hydraulic or pneumatic pressure. The valve position will be controlled by an electric solenoid valve activated from a float in the tank/reservoir. The valve and the controls will be a Dorot Series 100 valve or similar in all aspects.

Quick Sizing

- Valve size same as line or one size smaller
- Maximum flow speed for continuous operation 5.5 m/sec (18 ft/sec)

Design Considerations

- The valve should be suited for the maximal flow and allowed headloss
- The valve can be opened by the electric command (NC) or closed by it (NO). The definition refers to the main valve operation and not to the solenoid's characteristics

Optional Control System Components:

- 1 Main Valve
- 2 Self-flushing filter
- 3 Cock valve*
- 4 3/2 Solenoid valve
- 5 Accelerator relay (optional for valves larger than 150mm/6")
- 6 Electric float switch

* Optional component

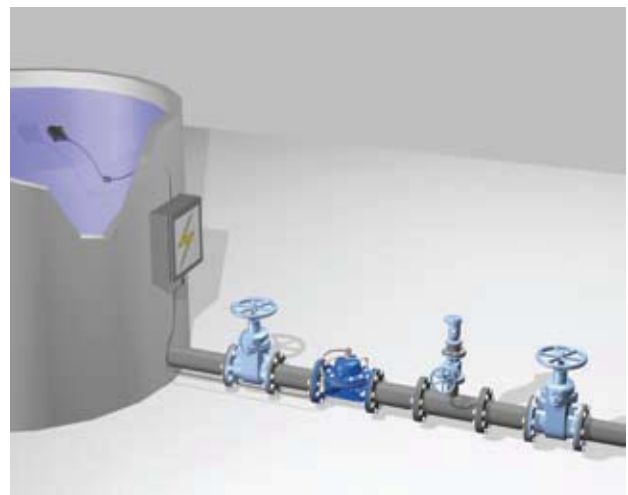

Typical Application

Dorot Electric Float Controlled Valve controlling the water volume in a tank.

FLDI Differential Float Controlled Valve

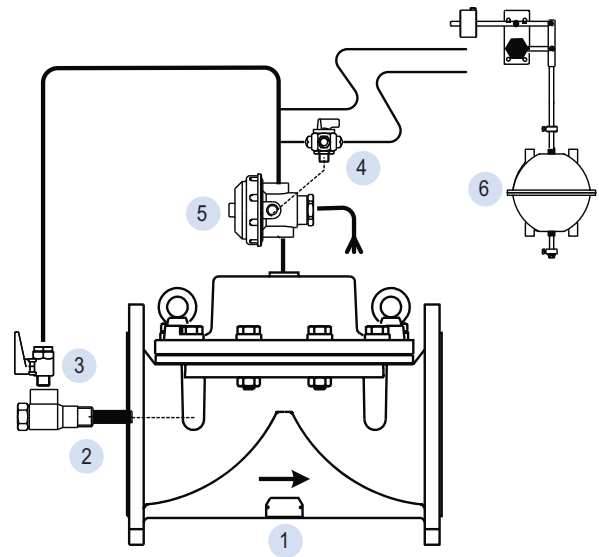

Description

A float valve controls the main valve, closing it when the water reaches maximum level, and opening it when the water drops to its preset minimum level. The differential between the maximum and the minimum levels is adjustable.
 Optional Addition: Stepped Surge-Preventing Closure.

Features

- Accurate and repeatable differential level control
- Adjustable differential
- Fast response
- Simple and reliable design
- Easy installation and maintenance

Purchase Specifications

The valve will be hydraulic, direct sealing diaphragm type, which allows inline maintenance. No stem, shaft or guide bearing will be located within the water passage.
 The valve will be activated by the line pressure or by an external hydraulic pressure. The valve position will be controlled by a 4-way float pilot located at the top of the tank/reservoir. The valve and the controls will be a Dorot Series 100 valve or similar in all aspects.

Quick Sizing

- Valve size same as line or one size smaller
- Maximum flow speed for continuous operation 5.5 m/sec (18 ft/sec)

Design Considerations

- The valve should be suited for the maximal flow
- Upstream pressure at closed position should be at least 10m (15psi) higher than the static water pressure at the downstream
- Fast stream and waves may cause mechanical damage to the float levers. It is advisable to install the pilot in a still part of the reservoir

Optional Control System Components:

- 1 Main Valve
- 2 Self-flushing filter
- 3 Cock valve*
- 4 Manual over-ride selector valve*
- 5 Accelerator relay (optional for valves larger than 150mm/6")
- 6 4-way differential pilot valve (other types are optional)

* Optional component

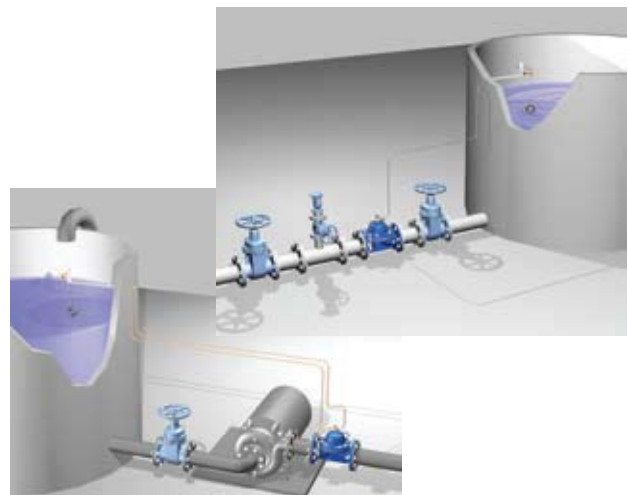

Typical Application

Dorot Differential Float Pilot Controlled Valve controlling the water volume in a filling or emptying tank.

AL Altitude Pilot Controlled Valve



Description

The main valve is controlled by a highly sensitive pilot, located outside the tank. The pilot opens or closes the valve in response to the static pressure of the water. The pilot allows for differential adjustments between the maximum and minimum level. Optional Addition: Stepped Surge-Preventing Closure.

Features

- Accurate and repeatable differential level control
- Fast response
- Easy access - no float is located in the tank/reservoir
- Simple and reliable design
- Easy installation and maintenance

Purchase Specifications

The valve will be hydraulic, direct sealing diaphragm type, which allows inline maintenance. No stem, shaft or guide bearing will be located within the water passage.

The valve will be activated by the line pressure or by an external hydraulic or pneumatic pressure. The valve position will be controlled by a hydrostatic pressure sensing pilot valve. The valve and the controls will be a Dorot Series 100 valve or similar in all aspects.

Quick Sizing

- Valve size same as line or one size smaller
- Maximum flow speed for continuous operation 5.5 m/sec (18 ft/sec)

Design Considerations

- The valve should be suited for the maximal flow
- The pilot valve must be located at least 2 meters below the closing level in the tank
- When water-hammer/surge expected during closure - add stepped surge preventing closure function to the altitude control pilot

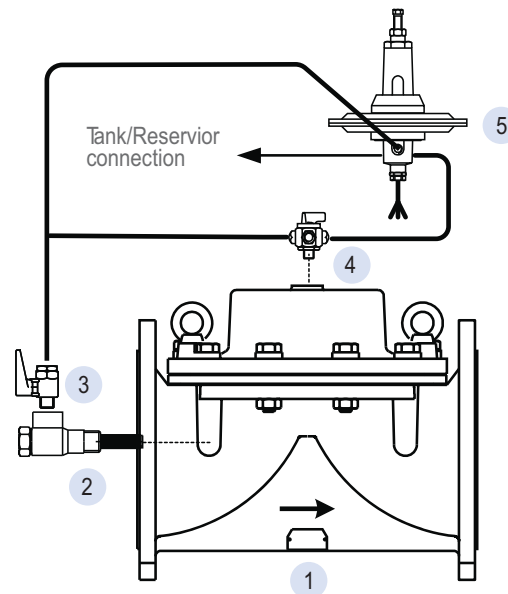

Optional Control System Components:

- 1 Main Valve
- 2 Self-flushing filter
- 3 Cock valve*
- 4 Manual over-ride selector valve*
- 5 High sensitivity altitude control pilot valve

* Optional component

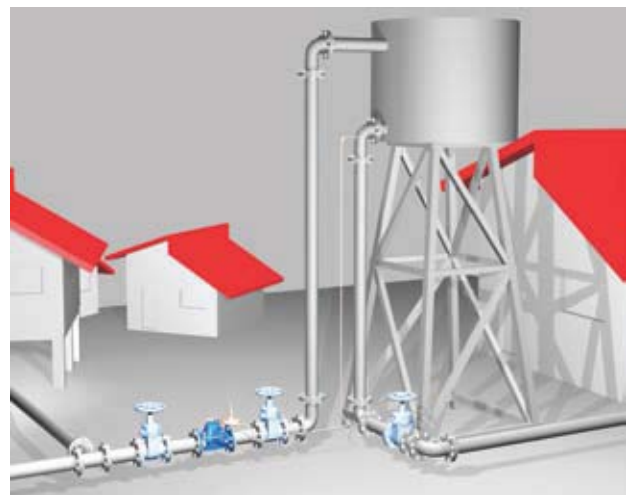

Typical Application

Dorot Altitude Pilot Controlled Valve controlling the water volume in an elevated tank.

BC Booster Pump Control Valve



Description

The valve eliminates damaging surges caused by pump start-up and shut-off. The electrically activated valve gradually opens on pump start up, and slowly closes before the pump is switched off. The valve will automatically close drip tight in case of power failure. Optional Additions: Flow Rate Limitation, Extended Closure, Two Stage Operating, Pressure Reducing and Pressure Sustaining.

Features

- No slam operation
- Exceptionally low losses at high flow conditions
- Simple and reliable design
- Easy installation and maintenance

Purchase Specifications

The valve will be hydraulic, direct sealing diaphragm type, which allows inline maintenance. No stem, shaft or guide bearing will be located within the water passage. The valve will be activated by the line pressure or by an external hydraulic or pneumatic pressure. The valve position will be controlled by an electric solenoid valve with adjustable open close speed control valves. The valve and the controls will be a Dorot Series 100 valve or similar in all aspects.

Quick Sizing

- Valve size same as line or one size smaller
- Maximum flow speed for continuous operation 5.5 m/sec (18 ft/sec)

Design Considerations

- The valve should be suited for the maximal flow
- Closure time is related to the pipe length and should be extended for longer pipe
- For power failure situations, add a fast reacting checkvalve in series and a surge anticipating valve to relief possible surges

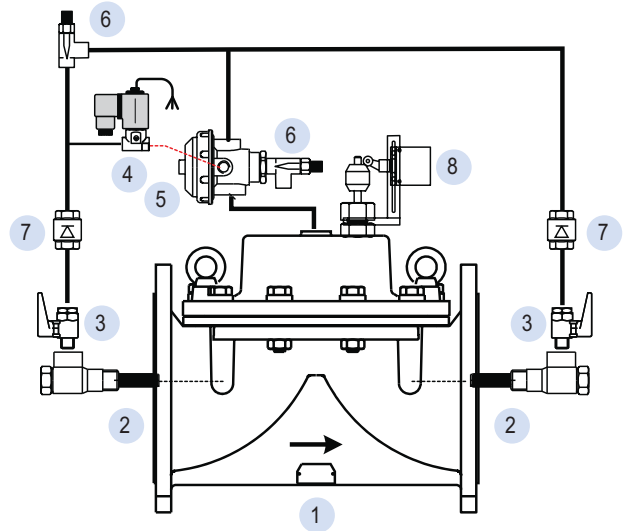

Optional Control System Components:

- 1 Main Valve
- 2 Self-flushing filter
- 3 Cock valve*
- 4 3/2 Solenoid valve
- 5 Accelerator relay (optional for valves larger than 150mm/6")
- 6 Open/close speed adjustment needle valve
- 7 Check valve
- 8 Limit switch assembly

* Optional component

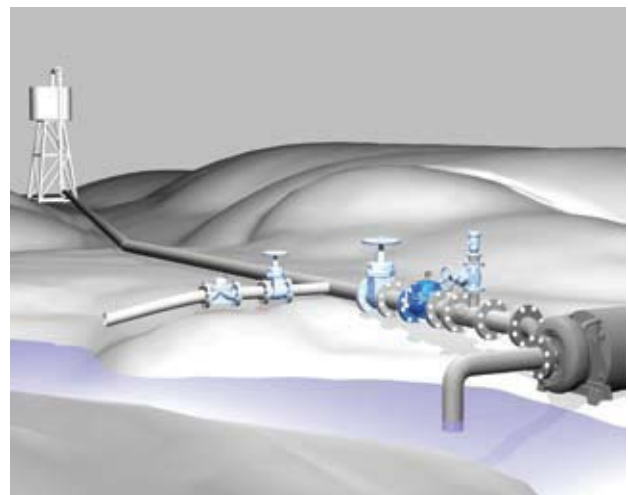

Typical Application

Dorot Booster Pump Control Valve preventing surges caused by pump startup and shutoff and drainage of main pipe.

DW Deep Well (Borehole) Pump Control Valve



Description

The valve eliminates surges caused by the start-up and shut-off of vertical or submersible pumps. It is a relief valve, assembled on a T-junction of the main pipeline. When the pump starts, the valve slowly closes, gradually increasing network pressure. Before pump shut-off, the valve slowly opens, gradually reducing network pressure.

Features

- No slam operation
- Simple and reliable design
- Easy installation and maintenance
- Low Resistance and high flow capacity

Purchase Specifications

The valve will be hydraulic, direct sealing diaphragm type, which allows inline maintenance. No stem, shaft or guide bearing will be located within the water passage. The valve will be activated by the line pressure or by an external hydraulic or pneumatic pressure. The valve position will be controlled by an electric solenoid valve with adjustable open/close speed control valves. The valve and the controls will be a Dorot Series 100 valve or similar in all aspects.

Quick Sizing

- The valve should be sized to match the well flow at 5 mwc/8 psi in the valve site (pump head water table depth):

$$D[\text{mm}] \geq 170 \times \sqrt{\text{Flow} [\text{m}^3/\text{hr}]}$$

$$D[\text{inch}] \geq 0.55 \times \sqrt{\text{Flow} [\text{gpm}]}$$

Design Considerations

- The valve should be suited for the maximal flow
- Closure time is related to the pipe length and should be extended for longer pipe
- For power failure situations, add a fast reacting checkvalve in series and a surge anticipating valve to relief possible surges

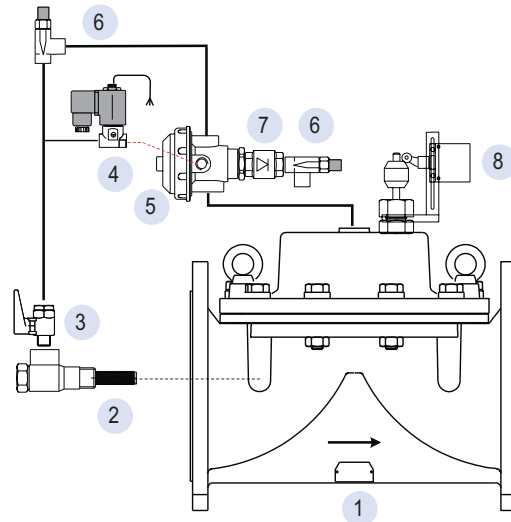

Optional Control System Components:

- 1 Main Valve
- 2 Self-flushing filter
- 3 Cock valve*
- 4 3/2 Solenoid valve
- 5 Accelerator relay (optional for valves larger than 150mm/6")
- 6 Open/close speed adjustment needle valve
- 7 Check valve
- 8 Limit switch assembly

* Optional component

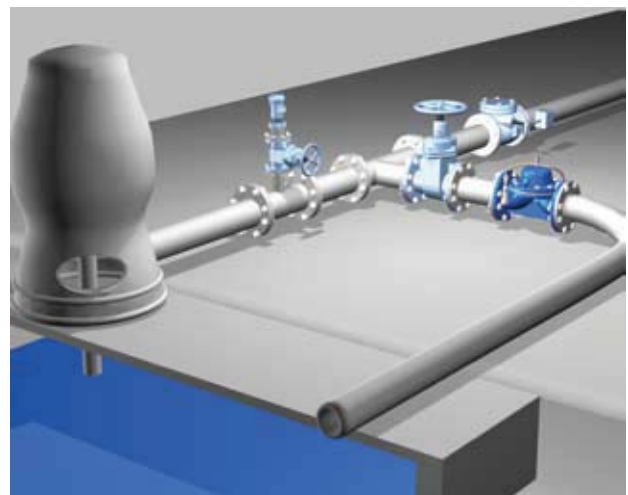

Typical Application

Dorot Deep Well Pump Control Valve preventing surges caused by pump start-up or shut-off.

RE Surge Anticipating Valve



Description

The valve protects the pumping system from water hammer, caused by sudden pump shut-off (case of power failure, for example). The valve is assembled on a T-junction of the main pipeline, instantly opens when the pump stops, relieving the returning high pressure wave. The valve slowly closes once the pressure returns to the static level. The valve also functions as a pressure relief valve.

Features

- No slam operation
- Simple and reliable design
- Easy installation and maintenance
- Low Resistance and high flow capacity
- Protection for sewage as well as clean water pumping systems

Purchase Specifications

The valve will be hydraulic, direct sealing diaphragm type, which allows inline maintenance. No stem, shaft or guide bearing will be located within the water passage. The valve will be activated by the line pressure or by an external hydraulic or pneumatic pressure. The valve will be operated by pressure relief pilot valve for opening at a low pressure set point and another pilot for pressure relief at a high pressure set-point. The valve and the controls will be a Dorot Series 100 valve or similar in all aspects.

Quick Sizing

- The valve should be sized to match the 80% of the normal flow at static head in the valve site:
 $D[\text{mm}] \leq \sqrt{(250 \times \text{Flow}[\text{m}^3/\text{hr}] / \sqrt{\text{Pressure}[\text{mwc}]})$
 $D[\text{inch}] \leq \sqrt{(0.109 \times \text{Flow}[\text{gpm}] / \sqrt{\text{Pressure}[\text{psi}]})$

Design Considerations

- Install a manual separation/throttling valve, upstream of the valve position
- Closure time is related to the pipe length and should be extended for longer pipe
- The valve sensor tube must be connected to the main line

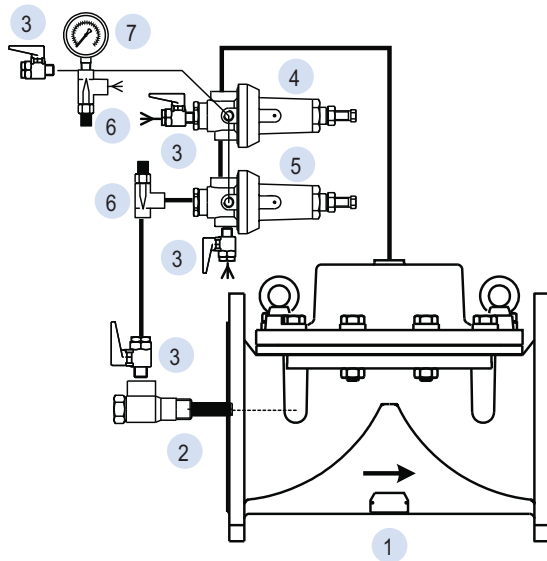

Optional Control System Components:

- 1 Main Valve
- 2 Self-flushing filter
- 3 Cock valve*
- 4 Low-pressure relief pilot valve
- 5 High-pressure relief pilot valve
- 6 Needle valve
- 7 Pressure gauge

* Optional component

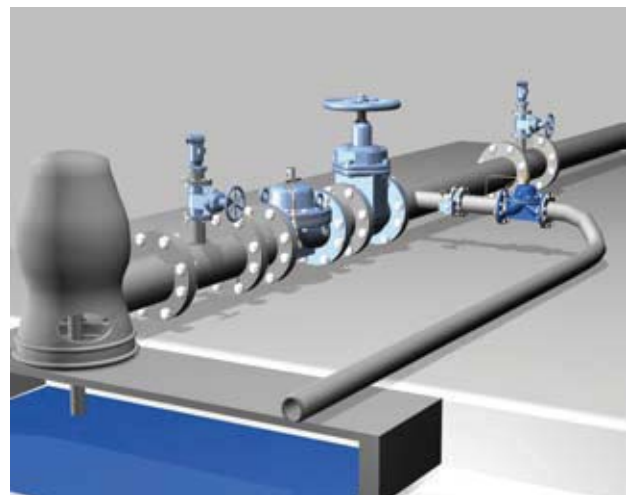

Typical Application

Dorot Surge Anticipating Valve prevents water-hammer surges caused by an un-expected pump shut-off.

QR Quick Pressure-relief Valve



Description

The valve opens instantly when the pressure in the pipeline exceeds the safe level, thus relieving excessive pressure from the network. When the pressure returns to normal, the valve closes slowly, at an adjustable pace.

Features

- No slam operation
- Simple and reliable design
- Easy installation and maintenance
- Low Resistance and high flow capacity
- Protection for sewage as well as clean water pumping systems

Purchase Specifications

The valve will be hydraulic, direct sealing diaphragm type, which allows inline maintenance. No stem, shaft or guide bearing will be located within the water passage. The valve will be activated by the line pressure or by an external hydraulic or pneumatic pressure. The valve will be operated by a pressure relief pilot valve for fast opening at a high pressure set-point. The valve and the controls will be a Dorot Series 100 valve or similar in all aspects.

Quick Sizing

- The valve should be sized to match the expected relief flow at the set opening pressure:
 $D[\text{mm}] \leq \sqrt{(250 \times \text{Flow}[\text{m}^3/\text{hr}] / \sqrt{\text{Pressure}[\text{mwc}]})$
 $D[\text{inch}] \leq \sqrt{(0.109 \times \text{Flow}[\text{gpm}] / \sqrt{\text{Pressure}[\text{psi}]})$

Design Considerations

- Install a manual separation valve, upstream of the valve position
- Closure time is related to the pipe length and should be extended for longer pipe
- The valve opens instantly at the set pressure. For regulating the system pressure use a Pressure Sustaining Relief Valve and not a Quick Relief valve

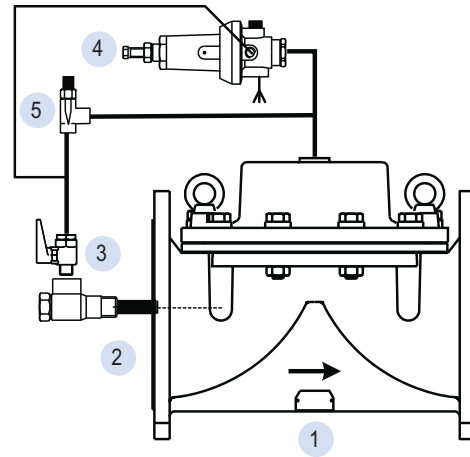

Optional Control System Components:

- 1 Main Valve
- 2 Self-flushing filter
- 3 Cock valve*
- 4 Pressure relief pilot valve
- 5 Needle valve

* Optional component

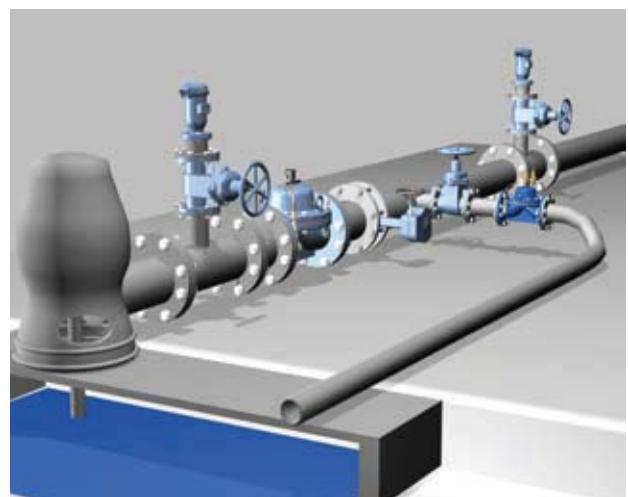

Typical Application

Dorot Quick Pressure-relief Valve protects a system against pressure surges caused by pump start-up or valves closure.

TO Two Stage Opening Addition



Description

The device can be added to any control function and will prevent damage caused by too fast filling of a drained pipeline. The flow rate will be restricted, until the network, downstream of the valve is full and then a full opening of the valve is enabled. Please consult DOROT for more details.

Features

- Can be added to any pipe-filling control function
- User adjusted filling pace
- Completely hydraulic – no electronic controllers, batteries or relays are used
- Simple and reliable design

Purchase Specifications

The valve will be hydraulic, direct sealing diaphragm type, which allows inline maintenance. No stem, shaft or guide bearing will be located within the water passage. The valve will be activated by the line pressure or by an external hydraulic or pneumatic pressure. The valve's opening will be restricted by a two-stage opening control that limits the filling flow until the downstream system is full. The valve and the controls will be a Dorot Series 100 valve or similar in all aspects.

Quick Sizing

- Valve size same as line or one size smaller
- Maximum flow speed for continuous operation 5.5 m/sec (18 ft/sec)

Design Considerations

- The valve should be suited for the maximal flow and allowed headloss
- Prefer selection low pressure diaphragms when the valve is expected to stay in open position for long periods

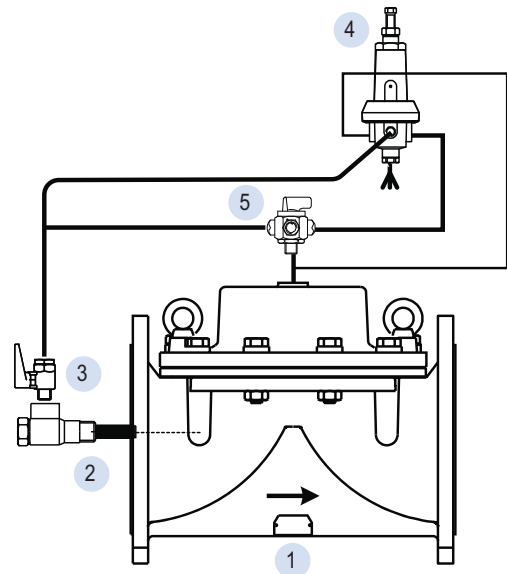

Optional Control System Components:

- 1 Main Valve
- 2 Self-flushing filter
- 3 Cock valve*
- 4 Pilot valve
- 5 3-way selector valve*

* Optional component

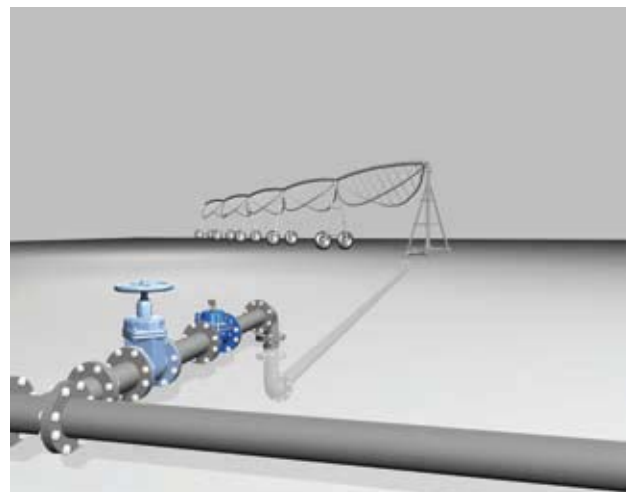

Typical Application

Dorot two-stage function prevents water-hammer/surges caused by fast drained pipe filling.

SP Surge Preventing Stepped-Closure Addition

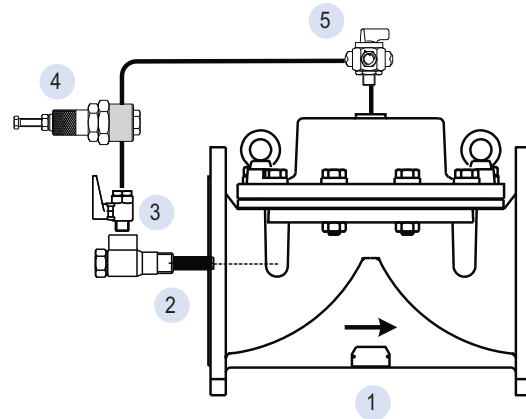

Description

The device can be added to any control function and automatically adjusts the closing speed of a valve that is located at the end of a long pipeline. This ensures a moderate flow change pace that prevents pressure surges from evolving. Please consult DOROT for more details

Features

- Can be added to any fast closing control function
- Automatically self-adjusted closing pace
- Completely hydraulic – no electronic controllers, batteries or relays are used
- Simple and reliable design

Purchase Specifications

The valve will be hydraulic, direct sealing diaphragm type, which allows inline maintenance. No stem, shaft or guide bearing will be located within the water passage.

The valve will be activated by the line pressure or by an external hydraulic or pneumatic pressure. The valve's closure pace will be controlled by a stepped closure control pilot that stops the closing procedure whenever surge waterhammer conditions evolve. The valve and the controls will be a Dorot Series 100 valve or similar in all aspects.

Quick Sizing

- Valve size same as line or one size smaller
- Maximum flow speed for continuous operation 5.5 m/sec (18 ft/sec)

Design Considerations

- The valve should be suited for the maximal flow and allowed headloss
- Prefer selection low pressure diaphragms when the valve is expected to stay in open position for long periods
- Should be used whenever the supply pipe is longer than 2 km/ 1.2 mile and the flow speed exceeds 1.5 m/sec

Optional Control System Components:

- 1 Main Valve
- 2 Self-flushing filter
- 3 Cock valve*
- 4 Stepped closure adjusting pilot valve
- 5 3-way selector valve*

* Optional component

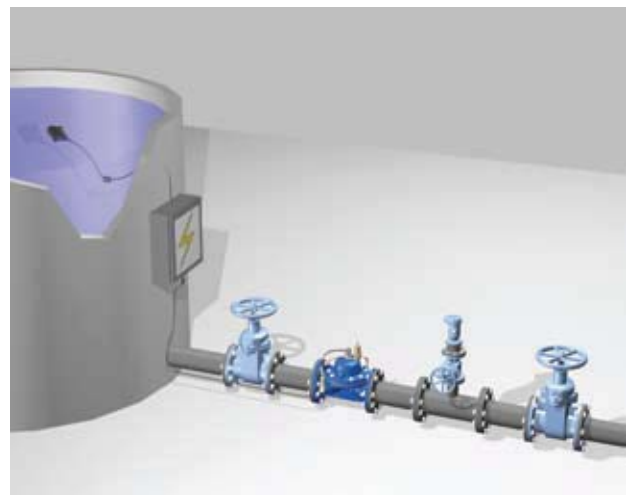

Typical Application

Dorot stepped closure function prevents water-hammer surges caused by fast closing level control valve.

EC PLC Controlled Valve



Description

The valve is controlled by a PLC controller that enables local or remote control of various functions such as, time related operation, the batching of liquid, and conditional (automatically modified) control parameters, in various applications. A recommended option is using the Dorot "ConDor" controller that enables the selection from a vast range of pre-programmed control functions and their combinations.

Features

- Can perform any control function
- Highly accurate and reliable electronic control
- Low power actuation
- Simple and reliable design
- Controlled by Dorot ConDor valve controller or by a third party controller

Purchase Specifications

The valve will be hydraulic, direct sealing diaphragm type, which allows inline maintenance. No stem, shaft or guide bearing will be located within the water passage. The valve will be activated by the line pressure or by an external hydraulic or pneumatic pressure. The valve position will be determined by a set of two solenoid valves controlled by a PLC controller. The valve and the controls will be a Dorot Series 100 valve or similar in all aspects.

Quick Sizing

- Valve size same as line or one size smaller
- Maximum flow speed for continuous operation 5.5 m/sec (18 ft/sec)

Design Considerations

- The valve should be suited for the maximal flow and allowed headloss
- Solenoid wiring diameter should be selected so that the activation voltage - losses will equal the rated value $\pm 10\%$

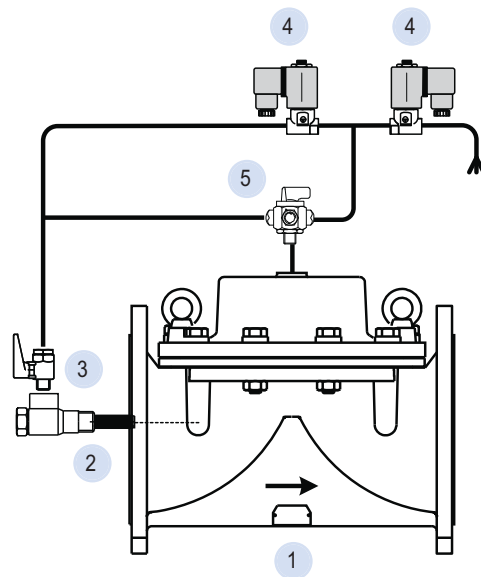

Optional Control System Components:

- 1 Main Valve
- 2 Self-flushing filter
- 3 Cock valve*
- 4 2/2, NC solenoid valve
- 5 3-way selector valve*

* Optional component

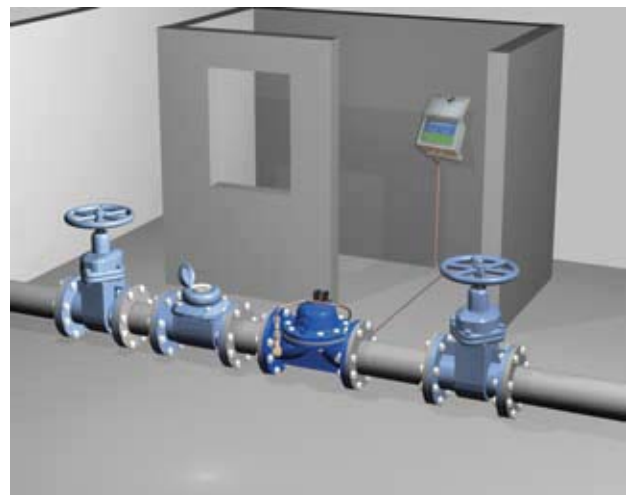

Typical Application

Dorot PLC Controlled Valve adjusts the flow rate following a set-point signal sent from a remote center.

DE Deluge Dry-pipe and Pre-action Valves

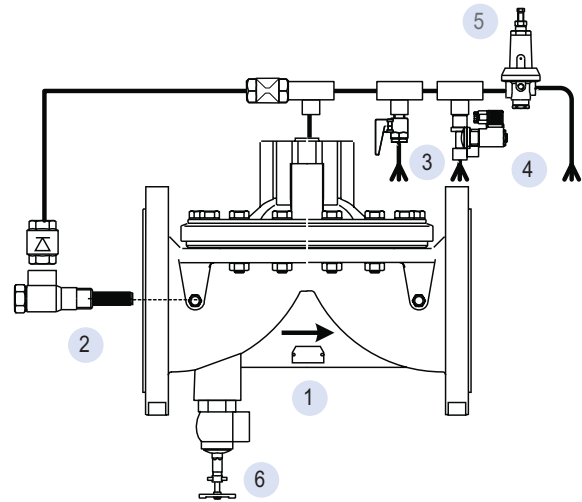
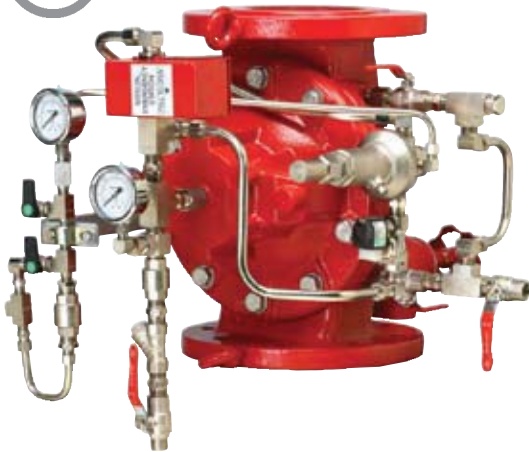

Description

The valve prevents flow of water into fire extinguishing sprinklers system until it is activated by the activation devices. Different valve and control system configurations are available to meet the customer and relevant standards demands. Please check Dorot Fire-Fighting publications for further information.

Features

- Fast opening
- Simple and reliable design
- Automatic reset
- Wide range of applications
- UL Approval no. VLFT EX.6543

Purchase Specifications

The valve will be hydraulic, direct sealing diaphragm type, which allows inline maintenance. No stem, shaft or guide bearing will be located with in the water passage.

The valve will be activated by the line pressure or by an external hydraulic or pneumatic pressure. The valve and the controls will be a Dorot Series 100 valve or similar in all aspects.

Quick Sizing

- Valve size same as line or one size smaller
- Maximum flow speed for intermittent operation 8 m/sec (26 ft/sec)

Design Considerations

- The valve should be suited for the maximal flow and allowed headloss
- Check Dorot catalogue for Fire Fighting Valves for more information with regards to valve and applications types

Optional Control System Components:

- 1 Main Valve
- 2 Self-flushing filter
- 3 Manual activation valve
- 4 Solenoid activation*
- 5 Pilot activation (by detection line)*
- 6 Drain valve

* Optional component

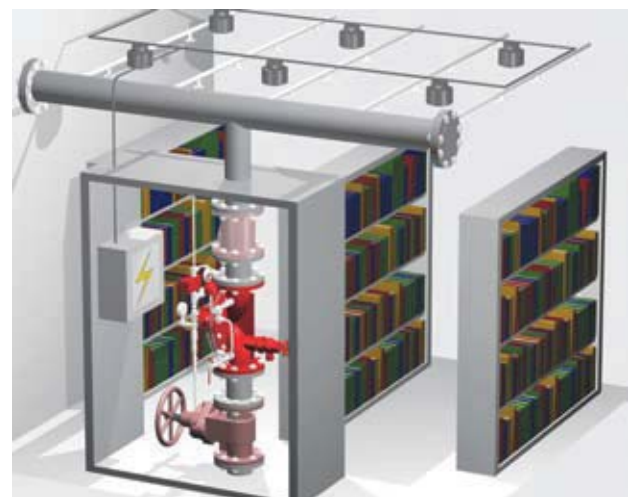

Typical Application

Dorot valve, activated by a sprinkler detection line.

Pilots and Accessories

Plastic Mini Pilots

For valve sizes 20mm to 100mm - 3/4" to 4"
 Pressure rating: 10 bar / 145 psi

29-100	3-way pressure reducing pilot valve
29-200	3-way multi purpose (pressure reducing and sustaining) pilot valve
29-300	3 way differential multi purpose (flow control, differential pressure sustaining)



Metal Mini Pilots

For valve sizes 20mm to 150mm - 3/4" to 6"
 Pressure rating: 25 bar / 360 psi

68-410	2-way pressure reducing pilot valve
68-500	2-way pressure sustaining pilot valve
68-220	3-way (pressure rating 16bar / 230psi) pressure reducing pilot valve
31-10 R/F/S	3-way multi purpose (pressure reducing and sustaining, flow-control) pilot valve

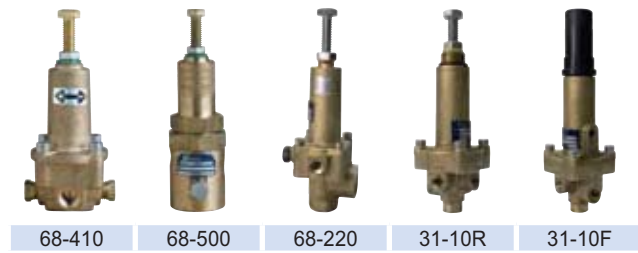

Metal Pilots

For valve sizes 40mm to 600mm - 1 1/2" to 24"
 Pressure rating: 25 bar / 360 psi

CXPR	2-way pressure reducing pilot valve (CXRS - remote sensing, CXRD differential pressure reducing)
CXPS	2-way pressure sustaining pilot valve (CXSD differential pressure sustaining)
31-310	3-way multi purpose (pressure reducing and sustaining) pilot valve
76-200	3 way differential multi purpose (flow control, differential pressure sustaining)
68-710	2-way pressure sustaining pilot valve



High Sensitivity Metal Pilots

For valve sizes 40mm to 600mm - 1 1/2" to 24"
 Pressure rating: 25 bar / 360 psi

70-110	3 way differential multi purpose (flow control, altitude control and differential pressure sustaining) with adjustable differential
70-410	2-way differential pressure reducing mini pilot valve (flow control and altitude control)
31-10H	3-way pressure reducing and differential control



Float Pilots

For valve sizes 40mm to 600mm - 1 1/2" to 24"
 Pressure rating: 25 bar / 360 psi

70-200	Electric float
70-550	Vertical, differential, 3 and 4-way metal float pilot
70-300	Modulating, 2-way plastic float pilot for irrigation use (pressure rating: 8 bar / 115 psi)
70-400	Modulating, 2-way metal float pilot
70-610	Horizontal, differential, 3-way metal float pilot

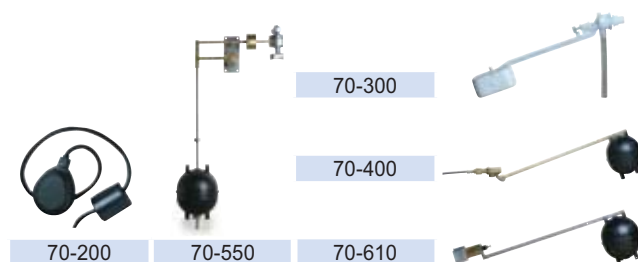

Plastic Relays

For valve sizes 20mm to 150mm - 3/4" to 6"
 Pressure rating: 10 bar / 145 psi

25-300	3-way / 2 positions NO w. 3/8" ports hydraulic relay
'Galit'	3-way / 2 positions NC or NO, small hydraulic relay

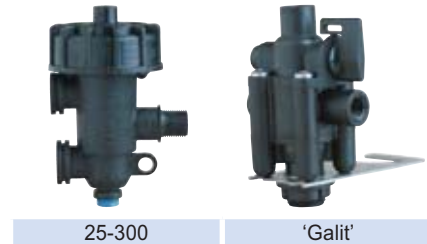

Metal Relays

For valve sizes 40mm to 600mm - 1 1/2" to 24"
 Pressure rating: 25 bar / 360 psi

66-210	3-way / 2 positions NO (66-213: NC) hydraulic relay
66-300	3-way adjustable hydraulic relay
28-200	2-way / 2 positions hydraulic relay
28-300	3-way / 2 positions hydraulic relay

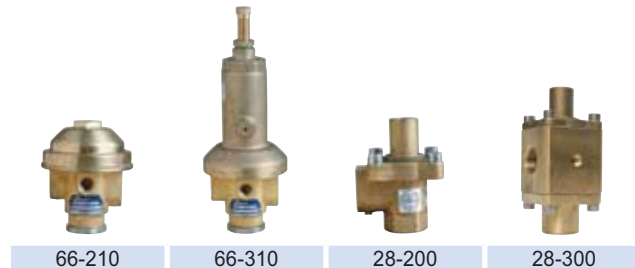

Mini Solenoids

For irrigation valve sizes 20mm to 150mm - 3/4" to 6"
 Pressure rating: 10 bar / 145 psi
 Operating Voltage:
 AC: 24V
 DC: 12V or 24V
 Latch 7.5-30V

D2	2-way NC solenoid valve
D3	3-way NC or NO solenoid valve



Heavy-duty Solenoids

For valve sizes 20mm to 600mm - 3/4" to 24"
 Pressure rating: According to the selected orifice and solenoid type
 Operating Voltage (others available upon request):
 AC: 24V, 110V or 220V
 DC: 12V or 24V
 Latch 9V, 12V, 24V

B2	2-way NC or NO solenoid valve
B3	3-way NC or NO solenoid valve

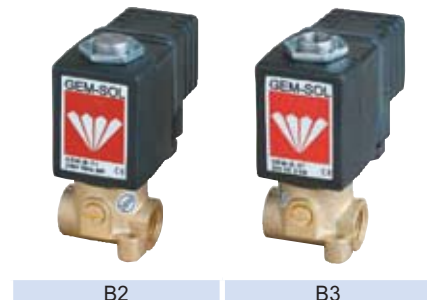

Control Filters

Self-Flushing, Inline - Stainless steel screen filter, located within the main valve, and rinsed continuously by the stream
 Sizes: 1/4", 1/2"
 External, "Y" type - Stainless steel screen installed in a "Y" shaped body on the pressure source.
 Sizes: 3/8", 1/2"
 External, large - A large volume external filter



Other Dorot Products

Automatic Control Valves



Series 300 - Disc seal, Globe type valve. Very accurate regulations at near zero flow conditions. Minimum head-loss while fully open. Available in sizes: 1.5" (40mm) - 32" (800mm).



Glass Reinforced Nylon Valves - Diaphragm sealing valves made of reinforced Polyamide used in Greenhouses, Field Crops, Irrigation, Landscaping, Water Treatment (non corrosive). Available in sizes: 3/4" (20mm) - 3" (80mm).



Series 500 - Disc seal, Y type valve. This valve is compact, partially made of new composite materials. Wide range of flow and pressure regulation. Available in sizes: 1.5" (40mm) - 8" (200mm).



Back Flushing Valves - Specially designed valves for back flow flushing of filtration systems. Available in Cast Iron or Glass Reinforced Nylon, Single or Double chamber operation. Available in sizes: 2" (50mm) - 4" (100mm).



uPVC Valves - Diaphragm sealing valves made of uPVC. For use with aggressive water and with underground (PVC) piping. Available in sizes: 3" (80mm) - 6" (150mm).

Manual Valves



Butterfly Valves - Soft sealing valves (Wafer type) with options of gear, lever (or other) operation. Available in sizes: 2" (50mm) - 24" (600mm).



Non Return Valves - Swing check valves, tilting disc check valves, double flap check valves.



Gate Valves - Valves with soft and resilient or rigid sealing.

Air Release Valves



Non Metal Air Release Valves - Kinetic, Automatic and Combination Air Release Valves made of Polypropylene materials. Available in sizes: 1/2" (12mm) - 2" (50mm).



Ductile Iron Air Release Valves - Kinetic, Combination and Sewage Air Release Valves made of ductile iron. Option for surge arrestor feature. Available in sizes: 2" (50mm) - 12" (300mm).

Water Meters



Water Meters - Multi-Jet, Single-Jet, Irrigation Meters (pelton wheel type), Woltman Meters and Volumetric Meters. Available in sizes: 1/2" (15mm) - 24" (600mm).

Typical Applications

Control applications

in water supply



Sewerage

fire fighting



irrigation systems

industrial



DOROT AUTOMATIC CONTROL VALVES

Founded in 1946, DOROT is a leading developer, manufacturer and marketer of a wide range of superior quality automatic control valves. DOROT's experienced Research & Development Dept. has a long tradition of generating innovative solutions for the application of water control systems. These include, waterworks distribution networks, sewage and effluent disposal, fire protection, mining and irrigation systems.

DOROT's commitment to excellence begins with using the highest quality materials. The company's engineering experts are constantly working to provide customers with a broad range of valve patterns and sizes in a wide variety of metals and grades including: Cast Iron, Ductile Iron, Cast Steel, SST, Bronze, Marine Bronze, Polyamide and P.V.C.

The experts at DOROT custom-design each valve application according to specific control requirements. Most of the production process, which includes machining and coating, takes place in modern in-house facilities. Before leaving the factory, each product is hydraulically tested. An advanced testing laboratory simulates the anticipated field conditions.

With distribution in more than 70 countries world-wide, a key component of the DOROT difference is its outstanding customer service. This includes field assistance, technical advice, training programs and follow-up consultations.

It is all of these factors that make DOROT a leader in fluid control technology and customer satisfaction.